

Your Global Automation Partner

TURCK

RI...-QR24

Encoders with IO-Link Interface

Instructions for Use



Contents

1	About these instructions	5
1.1	Target groups.....	5
1.2	Explanation of symbols used	5
1.3	Other documents	5
1.4	Feedback about these instructions.....	5
2	Notes on the product	6
2.1	Product identification.....	6
2.2	Scope of delivery	6
2.3	Turck service.....	6
3	For your safety	7
3.1	Intended use.....	7
3.2	Obvious misuse.....	7
3.3	General safety notes	7
4	Product description	8
4.1	Device overview	8
4.1.1	Indication elements	8
4.2	Properties and features.....	9
4.3	Operating principle.....	9
4.4	Functions and operating modes	9
4.4.1	IO-Link mode.....	9
4.5	Encoders — components and accessories	10
4.5.1	Encoder — QR24 sensor.....	10
4.5.2	Encoder — QR24 positioning element.....	10
4.5.3	Encoders — QR24 adapter sleeves.....	13
4.5.4	Encoders — protecting rings and mounting sets for QR24 device types	15
4.5.5	Encoders — general accessories.....	16
5	Installing	17
5.1	Front mounting — shaft diameters up to 20 mm	18
5.2	Rear mounting — shaft diameters up to 20 mm.....	19
5.3	Mounting on large rotatable machine part.....	20
6	Connection	21
6.1	Wiring diagram	21
7	Commissioning	22
7.1	Setting IO-Link mode.....	22
8	Operation	23
8.1	Maximum speed	23
8.2	LED display	23
9	Setting	24
9.1	Setting via IO-Link.....	24
9.1.1	IO-Link parameters.....	24
9.1.2	IO-Link process data.....	24
10	Troubleshooting	25
11	Maintenance	26

12	Repair	26
12.1	Returning devices.....	26
13	Decommissioning.....	26
14	Disposal	26
15	Technical data	27
16	Turck subsidiaries — contact information	28

1 About these instructions

These instructions for use describe the structure, functions and the use of the product and will help you to operate the product as intended. Read these instructions carefully before using the product. This is to avoid possible damage to persons, property or the device. Retain the instructions for future use during the service life of the product. If the product is passed on, pass on these instructions as well.

1.1 Target groups

These instructions are aimed at qualified personal and must be carefully read by anyone mounting, commissioning, operating, maintaining, dismantling or disposing of the device.

1.2 Explanation of symbols used

The following symbols are used in these instructions:



DANGER

DANGER indicates a dangerous situation with high risk of death or severe injury if not avoided.



WARNING

WARNING indicates a dangerous situation with medium risk of death or severe injury if not avoided.



CAUTION

CAUTION indicates a dangerous situation of medium risk which may result in minor or moderate injury if not avoided.



NOTICE

NOTICE indicates a situation which may lead to property damage if not avoided.



NOTE

NOTE indicates tips, recommendations and useful information on specific actions and facts. The notes simplify your work and help you to avoid additional work.



CALL TO ACTION

This symbol denotes actions that the user must carry out.



RESULTS OF ACTION

This symbol denotes relevant results of actions.

1.3 Other documents

Besides this document, the following material can be found on the Internet at www.turck.com:

- Data sheet
- Quick Start Guide
- IO-Link parameters manual
- Commissioning manual IO-Link devices

1.4 Feedback about these instructions

We make every effort to ensure that these instructions are as informative and as clear as possible. If you have any suggestions for improving the design or if some information is missing in the document, please send your suggestions to techdoc@turck.com.

2 Notes on the product

2.1 Product identification

RI 360 P1 - QR24 M1 - IOL X2 - H1 1 4 1

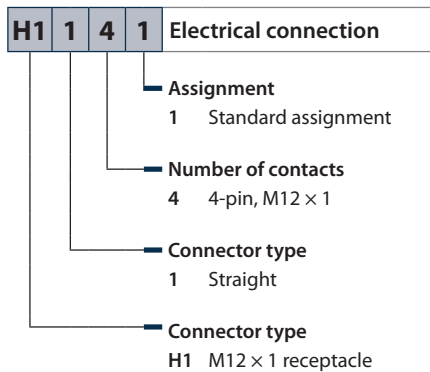
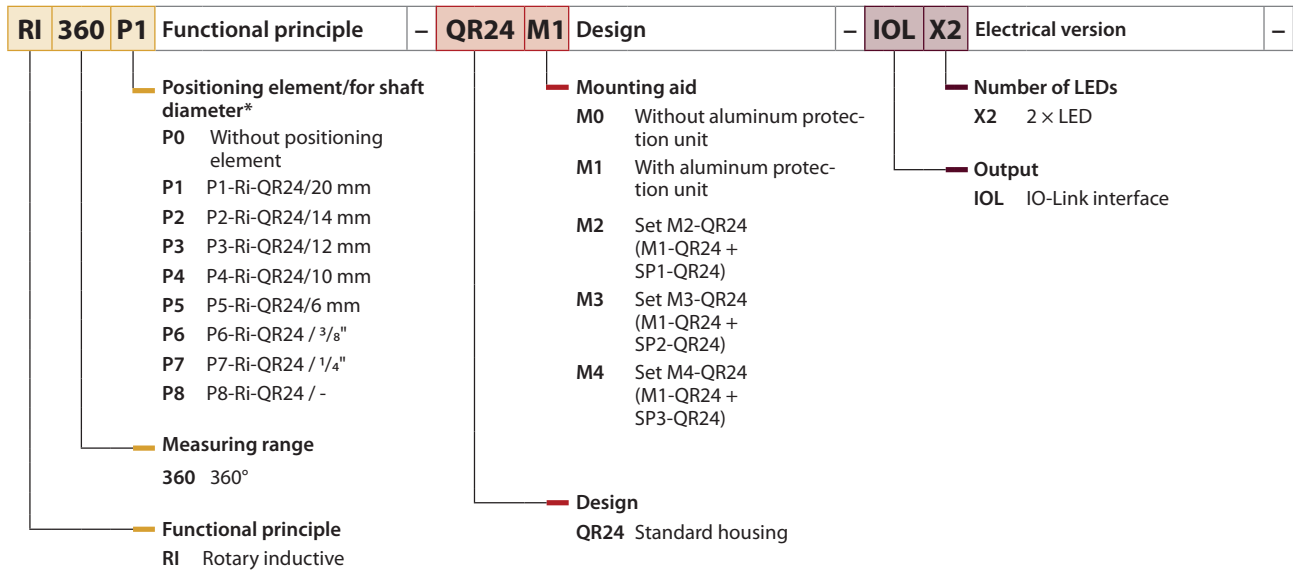

2.2 Scope of delivery

The scope of delivery includes:

- Encoder — sensor
- MT-QR24 mounting aid
- Quick Start Guide
- Optional: positioning element and mounting element

2.3 Turck service

Turck supports you with your projects, from initial analysis to the commissioning of your application. The Turck product database under www.turck.com contains software tools for programming, configuration or commissioning, data sheets and CAD files in numerous export formats.

The contact details of Turck subsidiaries worldwide can be found on p. [▶ 28].

3 For your safety

The product is designed according to state-of-the-art technology. However, residual risks still exist. Observe the following warnings and safety notices to prevent damage to persons and property. Turck accepts no liability for damage caused by failure to observe these warning and safety notices.

3.1 Intended use

The rotary encoders with an IO-Link interface are used for measuring speeds and angle movements. To do this the devices detect mechanical rotary movements and convert them into a digital IO-Link telegram. The devices can be operated and parameterized via an IO-Link interface with IO-Link masters compliant with specification 1.1. Process and diagnostics data can be exchanged with the higher controller level during operation via IO-Link.

The devices may only be used as described in these instructions. Any other use is not in accordance with the intended use. Turck accepts no liability for any resulting damage.

3.2 Obvious misuse

- The devices are not safety components and must not be used for personal or property protection.
- Any use that exceeds the maximum permissible mechanical speed (see technical data) is deemed to be not in accordance with the intended purpose.

3.3 General safety notes

- The device may only be assembled, installed, operated, parameterized and maintained by professionally-trained personnel.
- If safe operation can no longer be guaranteed: Shut down the device and lock out to prevent accidental startups.
- The device may only be used in accordance with applicable national and international regulations, standards and laws.
- The device meets the EMC requirements for industrial areas. When used in residential areas, take measures to avoid radio interference.

4 Product description

The inductive encoders of the RI360P-QR24 series measure speeds and angle movements up to 360°. The sensor and the positioning element of the encoders are fully encapsulated and designed as two independent and fully sealed units with protection to IP68K, which work together without contact. The optionally available adapter sleeves and mounting elements enable either the front or the rear of the encoder sensor to be fitted to shafts with a diameter of up to 20 mm. A mounting element for mounting on large rotatable machine parts is also provided in the program.

The devices are available as absolute encoders with different output functions and also as incremental encoders. A robust stainless steel EQR24 variant is available for use in the food and beverage industry.

The QR24 encoders with an IO-Link interface can be connected via a standard 4-pin male connector and a 3-wire connection cable. The devices can be operated and set via IO-Link.

4.1 Device overview

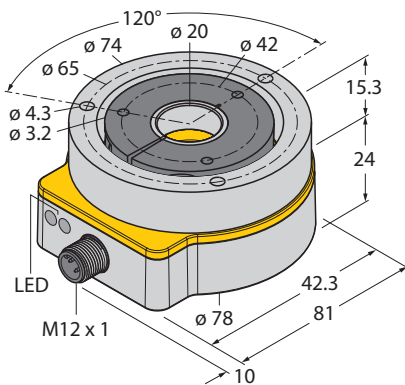

Fig. 1: QR24 encoder with sensor, P1 positioning element (optional) and protecting ring (optional)

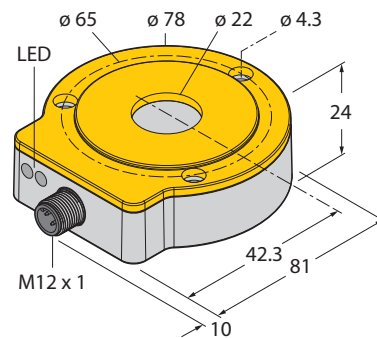

Fig. 2: Encoder — sensor (front)

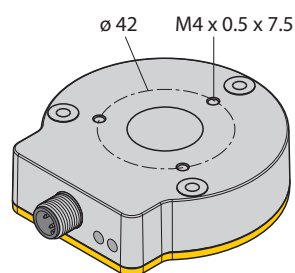

Fig. 3: Encoder — sensor (rear)

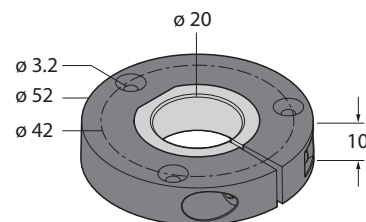

Fig. 4: Encoder — positioning element P1

4.1.1 Indication elements

The devices are provided with a green Power supply LED and a yellow Status LED.

4.2 Properties and features

- Operation and setting via IO-Link
- Single-turn, 16-bit resolution
- Process value in 32-bit IO-Link telegram
- 3 error bits
- 13 multiturn bits
- 16 single-turn bits
- Connection via 4-pin M12 × 1 male connector

4.3 Operating principle

The QR24 encoders have contactless operation based on the inductive resonant circuit measuring principle. This measuring principle makes it possible to design a fully encapsulated sensor housing without seals, which is separated from the positioning element. Magnetic fields cannot disturb the measuring process since the positioning element is not based on a magnet but on an inductive coil system, through which the sensor and the positioning element (resonator) can form an oscillation circuit. The inductive measuring principle of the QR24 encoder is absolute.

4.4 Functions and operating modes

The devices can be operated in IO-Link mode. The devices must be connected to an IO-Link master for operation in IO-Link mode. Different device functions can be configured via the IO-Link interface.

4.4.1 IO-Link mode

IO-Link mode provides bidirectional IO-Link communication between an IO-Link master and the sensors. For this the devices are integrated in the controller level via an IO-Link master. The switching signals are processed via the process data of the IO-Link interface. Besides the switching information, diagnostics and identification messages can be queried via IO-Link. The following device parameters can be adapted to the particular application via IO-Link:

- Device access protection
- Rotation direction
- Zero setting
- Multiturn reset
- Reset settings

4.5 Encoders — components and accessories

4.5.1 Encoder — QR24 sensor

Dimension drawing	Type	Description
	RI360P...-QR24	Encoder – sensor, QR24 design, die cast zinc housing (without positioning element)

4.5.2 Encoder — QR24 positioning element

The positioning elements are connected with the moving part of the machine (shaft) but move freely (without any mechanical connection to the sensor) over the active face of the sensor. Different reducing bushings are available to adapt the positioning element to the particular shaft diameter.

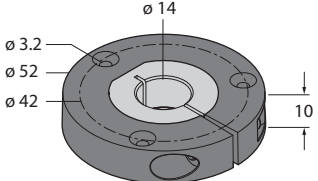
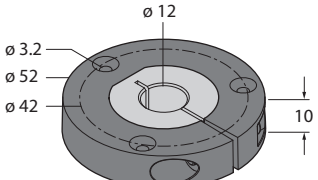
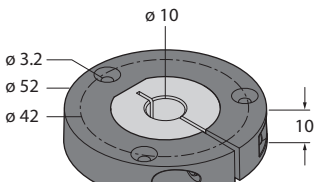
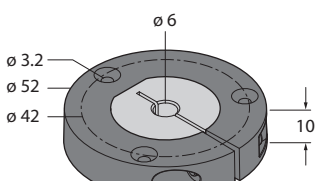

Dimension drawing	Type	Description
	PE1-QR24	Positioning element without reducing bushing with stainless steel fitting
	P1-RI-QR24	Positioning element with reducing bushing to connect to Ø 20 mm shafts

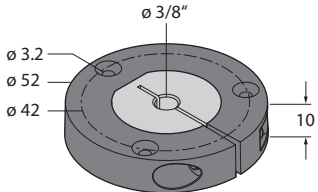
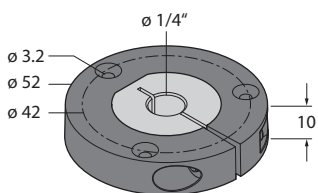
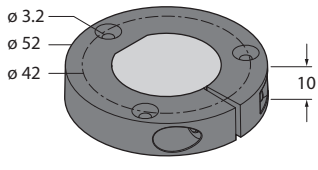
Dimension drawing	Type	Description
	P2-RI-QR24	Positioning element with reducing bushing to connect to Ø 14 mm shafts
	P3-RI-QR24	Positioning element with reducing bushing to connect to Ø 12 mm shafts
	P4-RI-QR24	Positioning element with reducing bushing to connect to Ø 10 mm shafts
	P5-RI-QR24	Positioning element with reducing bushing to connect to Ø 6 mm shafts

Dimension drawing	Type	Description
 <p>Technical drawing of a circular positioning element. It features a central hole with a diameter of $\varnothing 3/8"$. The outer diameter is $\varnothing 52$. There are four mounting holes, each with a diameter of $\varnothing 3.2$. The inner diameter of the ring is $\varnothing 42$. The thickness of the component is 10 units.</p>	P6-RI-QR24	Positioning element with reducing bushing to connect to $\varnothing 3/8"$ shafts
 <p>Technical drawing of a circular positioning element. It features a central hole with a diameter of $\varnothing 1/4"$. The outer diameter is $\varnothing 52$. There are four mounting holes, each with a diameter of $\varnothing 3.2$. The inner diameter of the ring is $\varnothing 42$. The thickness of the component is 10 units.</p>	P7-RI-QR24	Positioning element with reducing bushing to connect to $\varnothing 1/4"$ shafts
 <p>Technical drawing of a circular positioning element. It features a central hole with a diameter of $\varnothing 3/8"$. The outer diameter is $\varnothing 52$. There are four mounting holes, each with a diameter of $\varnothing 3.2$. The inner diameter of the ring is $\varnothing 42$. The thickness of the component is 10 units.</p>	P8-RI-QR24	Positioning element with blanking plug, e.g. for mounting on large rotatable machine parts

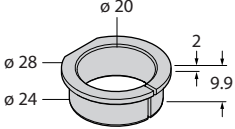
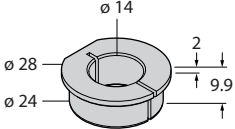
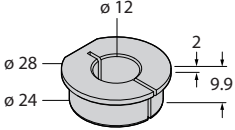
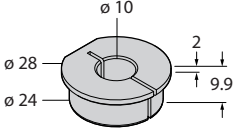
4.5.3 Encoders — QR24 adapter sleeves

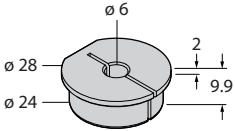
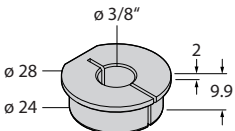
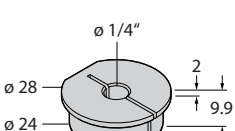
Dimension drawing	Type	Description
 <p>A technical drawing of a cylindrical adapter sleeve. The inner diameter is labeled as $\varnothing 20$. The outer diameter is labeled as $\varnothing 28$. The diameter of the central bore is labeled as $\varnothing 24$. The thickness of the sleeve is labeled as 2. The length of the sleeve is labeled as 9.9.</p>	<p>RA1-QR24</p>	<p>Reducing bushing to connect to $\varnothing 20$ mm shafts</p>
 <p>A technical drawing of a cylindrical adapter sleeve. The inner diameter is labeled as $\varnothing 14$. The outer diameter is labeled as $\varnothing 28$. The diameter of the central bore is labeled as $\varnothing 24$. The thickness of the sleeve is labeled as 2. The length of the sleeve is labeled as 9.9.</p>	<p>RA2-QR24</p>	<p>Reducing bushing to connect to $\varnothing 14$ mm shafts</p>
 <p>A technical drawing of a cylindrical adapter sleeve. The inner diameter is labeled as $\varnothing 12$. The outer diameter is labeled as $\varnothing 28$. The diameter of the central bore is labeled as $\varnothing 24$. The thickness of the sleeve is labeled as 2. The length of the sleeve is labeled as 9.9.</p>	<p>RA3-QR24</p>	<p>Reducing bushing to connect to $\varnothing 12$ mm shafts</p>
 <p>A technical drawing of a cylindrical adapter sleeve. The inner diameter is labeled as $\varnothing 10$. The outer diameter is labeled as $\varnothing 28$. The diameter of the central bore is labeled as $\varnothing 24$. The thickness of the sleeve is labeled as 2. The length of the sleeve is labeled as 9.9.</p>	<p>RA4-QR24</p>	<p>Reducing bushing to connect to $\varnothing 10$ mm shafts</p>

Dimension drawing	Type	Description
	RA5-QR24	Reducing bushing to connect to Ø 6 mm shafts
	RA6-QR24	Reducing bushing to connect to Ø 3/8" shafts
	RA7-QR24	Reducing bushing to connect to Ø 1/4" shafts
	RA8-QR24	Blanking plug for mounting without reducing bushing (e.g. mounting the positioning element on large rotatable machine parts)

4.5.4 Encoders — protecting rings and mounting sets for QR24 device types

Different mounting sets are required for different mounting types (see section “Installing”). Each mounting set contains an aluminum protecting ring and an aluminum shield plate. The shield plates enable the quality of the signal between the positioning element and the sensor to be increased depending on mounting type and application. The protecting rings are also available individually in aluminum and plastic.

Dimension drawing	Type	Description
	M1-QR24	Aluminum protecting ring
	M2-QR24	Mounting set (for front mounting of the sensor on shafts up to Ø 20 mm): Aluminum protecting ring M1-QR24 + Aluminum shield plate SP1-QR24: Ø 74 mm
	M3-QR24	Mounting set (for rear mounting of the sensor on shafts up to Ø 20 mm): Aluminum protecting ring M1-QR24 + Aluminum shield plate SP2-QR24: Ø 74 mm, with Ø 22 mm hole for shaft feedthrough

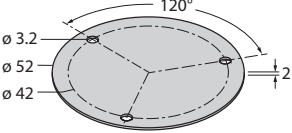
Dimension drawing	Type	Description
	M4-QR24	Mounting set (for mounting the positioning element on large rotatable machine parts): Aluminum protecting ring M1-QR24 + Aluminum shield plate SP3-QR24: Ø 52 mm

4.5.5 Encoders — general accessories

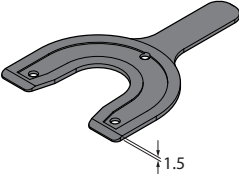
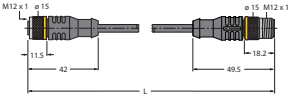
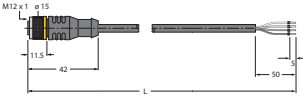
Dimension drawing	Type	Description
	MT-QR24	Mounting aid for optimum alignment of the positioning element (supplied)
	RKC4.4T-2-RSC4.4T/TXL	Connection cable, M12 female connector, straight 4-pin, M12 male connector, straight 4-pin, cable length: 2 m, jacket material: PUR, black; cULus approval; other cable lengths and qualities available, see www.turck.com
	RKC4.4T-2/TXL	Connection cable, M12 female connector, straight 4-pin, cable length: 2 m, jacket material: PVC, black; cULus approval; other cable lengths and qualities available, see www.turck.com

5 Installing

The optionally available adapter sleeves and mounting elements enable the front or rear of the encoder sensors to be fitted to the shafts with a diameter of up to 20 mm. With large rotatable machine parts, the positioning element is screwed directly onto the machine part and not fitted on the shaft.



WARNING

Improper fixing

Possible fatal injury from fast moving parts!

- ▶ Observe mounting instructions in all cases.
 - ▶ Check the secure seating of the positioning element, tightening torque:
M = 0.6...0.8 Nm.
-



NOTICE

Insufficient clearance from metal surrounding the positioning element

Loss of functionality due to weakening of resonant circuit

- ▶ Ensure sufficient clearance between the surrounding area and positioning element.
 - ▶ Carry out a function test prior to commissioning.
-



NOTE

The positioning element must be located in the middle of the measuring range of the sensor before the power supply is applied.

5.1 Front mounting — shaft diameters up to 20 mm

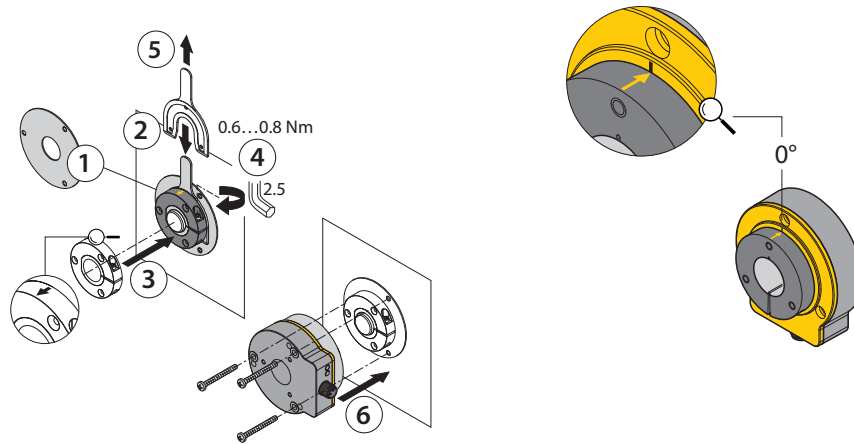

Fig. 5: Front mounting — shaft diameters up to 20 mm Fig. 6: Zero point default value

1. Use shield plate.
2. Mounting aid for optimum alignment of the positioning element.
3. Push the positioning element — with the front (active face) to the shaft — onto the shaft.
4. Fasten clamp fitting of the positioning element with hexagon spanner.
5. Remove mounting aid.
6. Place the encoder sensor including the protecting ring with the front to the shaft over the positioning element and align to the required position of the zero point. (factory setting for 0°: yellow arrow on the positioning element pointing to the black mark on the sensor, see figure “Zero point default value“.)
 - ▶ Fasten the encoder with three screws in order to obtain a closed and protected unit.

5.2 Rear mounting — shaft diameters up to 20 mm

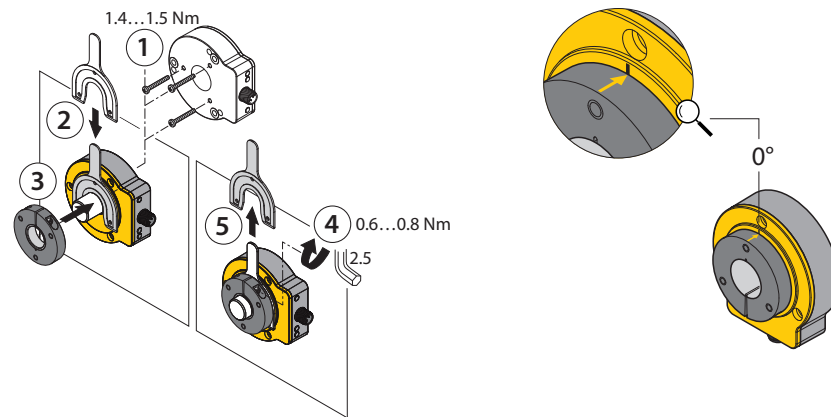

Fig. 7: Rear mounting — shaft diameters up to 20 mm

Fig. 8: Zero point default value

1. Push the encoder sensor — with the rear to the shaft — onto the shaft and fasten with three screws.
2. Mounting aid for optimum alignment of the positioning element.
3. Push the positioning element onto the shaft and align to the required position of the zero point. (factory setting for 0°: yellow arrow on the positioning element pointing to the black mark on the sensor, see figure “Zero point default value”.)
4. Fasten clamp fitting of the positioning element with hexagon spanner.
5. Remove mounting aid.
 - ▶ Optional: Use protecting ring and shield plate.

5.3 Mounting on large rotatable machine part

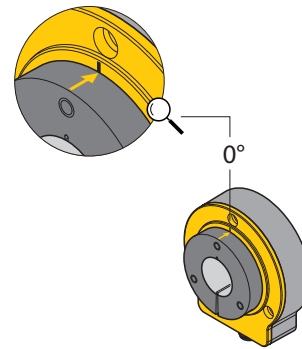
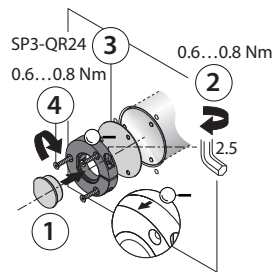

Fig. 9: Mounting on large rotatable machine part Fig. 10: Zero point default value part

1. If not yet present: Insert blanking plug into positioning element.
2. Fasten clamp fitting of the positioning element with hexagon spanner.
3. Use SP3-QR24 shield plate.
4. Fasten positioning element with three M3 countersunk screws (recommended: stainless steel screws).
 - ▶ Depending on the application, mount the encoder and align to the required position of the zero point (factory setting for 0°: yellow arrow on the positioning element pointing to the black mark on the sensor, see figure "Zero point default value".)

6 Connection

The encoder is provided with a 4-pin M12 × 1 male connector with an IO-Link interface.

- ▶ Connect the female connector of the connection cable to the M12 male connector of the device.
- ▶ Connect the open end of the connection cable to the IO-Link master, fieldbus device or controller with the appropriate inputs, according to the wiring diagram and the pin layout of the particular connected device.

6.1 Wiring diagram

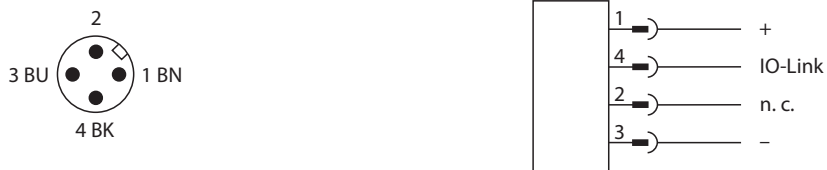

Fig. 11: M12 male connector — pin assignment Fig. 12: M12 male connector — wiring diagram

7 Commissioning

The device is operational automatically once the connection is made and the power supply is switched on. If the device is connected to an IO-Link master, IO-Link communication starts automatically. For this the IO-Link master sends a wakeup request to the device. The transfer speed depends on the transfer rate set in the IO-Link master.

7.1 Setting IO-Link mode

- ▶ Set the cycle time on the IO-Link master.
- ⇒ The device is operational.

8 Operation

The encoder supplies at the output the IO-Link process data corresponding proportionally to the position of the positioning element. The IO-Link process data contains the following information:

- Current angle information (single-turn data)
- Number of revolutions of the positioning element (Semi-multiturn data):
The multiturn process data is calculated internally from the number of single-turn zero crossings. The sensor does not detect any revolutions when de-energized. If the encoder is moved during a power failure, this is indicated on restart by a status bit. The status bit makes it possible to evaluate the correctness of the multiturn process data.

8.1 Maximum speed



WARNING

Improper fixing

Possible fatal injury from fast moving parts!

- ▶ Do not exceed the maximum speed of 800 rpm.
- ▶ Observe mounting instructions in all cases.
- ▶ Check the secure seating of the positioning element, tightening torque:
M = 0.6...0.8 Nm.

8.2 LED display

In normal operation the LEDs have the following indication functions:

Color/state	Meaning
Green flashing	Sensor power supply correct.
Yellow off	Positioning element is within the measuring range.
Yellow	Positioning element is within the measuring range, reduced signal quality (e.g. gap too large).
Yellow flashing	Positioning element is not within the measuring range.

9 Setting

The encoder can be set via the IO-Link interface.

9.1 Setting via IO-Link

The devices can be parameterized via the IO-Link communication interface within the limits of their technical specifications. For further information on IO-Link see the IO-Link commissioning manual (D900633).

9.1.1 IO-Link parameters

Different parameter settings for the particular application can be made via the IO-Link interface. For further information on IO-Link parameters see the IO-Link parameter manual.

The default values are shown in **bold type**.

Parameter	Parameter value
Block device access (switch off parameter server function)	On Off
Rotation direction	Clockwise Counter clockwise
Set zero point and reset multiturn	
Multiturn reset	
Reset to factory setting	
Application specific marking	

9.1.2 IO-Link process data

Process data (bit)				
0	1	2	3...15	16...31
Resonance coupling weak	No resonance coupling	Multiturn fault	Multiturn counter	Position

10 Troubleshooting

The strength of the resonance coupling is indicated by an LED. Any faults are indicated via the LEDs.

If the device does not function as expected, first check whether ambient interference is present. If there is no ambient interference present, check the connections of the device for faults.

If there are no faults, there is a device malfunction. In this case, decommission the device and replace it with a new device of the same type.

11 Maintenance

Ensure that the plug connections and cables are always in good condition.

The devices are maintenance-free, clean dry if required.

12 Repair

The device must not be repaired by the user. The device must be decommissioned if it is faulty. Observe our return acceptance conditions when returning the device to Turck.

12.1 Returning devices

Returns to Turck can only be accepted if the device has been equipped with a Decontamination declaration enclosed. The decontamination declaration can be downloaded from <https://www.turck.de/en/retoure-service-6079.php> and must be completely filled in, and affixed securely and weather-proof to the outside of the packaging.

13 Decommissioning

- ▶ Disconnect the connection cable from the power supply and/or processing units.
- ▶ Disconnect the connection cable from the device.
- ▶ Undo the connections of the device or if necessary the mounting aid for the mounting area.
- ▶ If present: undo the connection between the device and the mounting aid.

14 Disposal



The devices must be disposed of correctly and must not be included in general household garbage.

15 Technical data

Technical data	
Max. speed	800 rpm
Starting torque, shaft load (radial/axial)	Not applicable with contactless measuring principle
Nominal distance	1.5 mm
Resolution	16-bit
Measuring range	0...360°
Repetition accuracy	≤ 0.01 % of full scale
Linearity tolerance	≤ 0.05 % of full scale
Temperature drift	≤ ± 0.003 % / K
Ambient temperature	-25...+85 °C
Operating voltage	10...30 VDC
Ripple	≤ 10 % U _{ss}
Rated insulation voltage	≤ 0.5 kV
Output function	4-pin, IO-Link
Output type	Absolute semi-multiturn
Sampling rate	1000 Hz
Current consumption	< 50 mA
IO-Link specification	Specified according to version 1.1
Parameterization	FDT/DTM
Process data width	32-bit
Dimensions	81 × 78 × 24 mm
Shaft type	Hollow shaft
Housing material	Metal/plastic, ZnAlCu1/PBT-GF30-V0
Connection	Male connector, M12 x 1
Vibration resistance	55 Hz (1 mm)
Vibration resistance (EN 60068-2-6)	20 g, 10...3000 Hz, 50 cycles, 3 axes
Shock resistance (EN 60068-2-27)	100 g, 11 ms ½ sine, 3 × each, 3 axes
Continuous shock resistance (EN 60068-2-29)	40 g, 6 ms ½ sine, 4000 × each, 3 axes
Type of protection	IP68/IP69K
MTTF	138 years acc. to SN 29500 (Ed. 99) 40 °C
Operating voltage indication	LED green
Status display	LED yellow

16 Turck subsidiaries — contact information

Germany	Hans Turck GmbH & Co. KG Witzlebenstraße 7, 45472 Mülheim an der Ruhr www.turck.de
Australia	Turck Australia Pty Ltd Building 4, 19-25 Duerdin Street, Notting Hill, 3168 Victoria www.turck.com.au
Belgium	TURCK MULTIPROX Lion d'Orweg 12, B-9300 Aalst www.multiprox.be
Brazil	Turck do Brasil Automação Ltda. Rua Anjo Custódio Nr. 42, Jardim Anália Franco, CEP 03358-040 São Paulo www.turck.com.br
China	Turck (Tianjin) Sensor Co. Ltd. 18,4th Xinghuazhi Road, Xiqing Economic Development Area, 300381 Tianjin www.turck.com.cn
France	TURCK BANNER S.A.S. 11 rue de Courtalin Bat C, Magny Le Hongre, F-77703 MARNE LA VALLEE Cedex 4 www.turckbanner.fr
Great Britain	TURCK BANNER LIMITED Blenheim House, Hurricane Way, GB-SS11 8YT Wickford, Essex www.turckbanner.co.uk
India	TURCK India Automation Pvt. Ltd. 401-403 Aurum Avenue, Survey. No 109 /4, Near Cummins Complex, Baner-Balewadi Link Rd., 411045 Pune - Maharashtra www.turck.co.in
Italy	TURCK BANNER S.R.L. Via San Domenico 5, IT-20008 Bareggio (MI) www.turckbanner.it
Japan	TURCK Japan Corporation Syuuhou Bldg. 6F, 2-13-12, Kanda-Sudacho, Chiyoda-ku, 101-0041 Tokyo www.turck.jp
Canada	Turck Canada Inc. 140 Duffield Drive, CDN-Markham, Ontario L6G 1B5 www.turck.ca
Korea	Turck Korea Co, Ltd. B-509 Gwangmyeong Technopark, 60 Haan-ro, Gwangmyeong-si, 14322 Gyeonggi-Do www.turck.kr
Malaysia	Turck Banner Malaysia Sdn Bhd Unit A-23A-08, Tower A, Pinnacle Petaling Jaya, Jalan Utara C, 46200 Petaling Jaya Selangor www.turckbanner.my

Mexico	Turck Comercial, S. de RL de CV Blvd. Campestre No. 100, Parque Industrial SERVER, C.P. 25350 Arteaga, Coahuila www.turck.com.mx
Netherlands	Turck B. V. Ruiterlaan 7, NL-8019 BN Zwolle www.turck.nl
Austria	Turck GmbH Graumanngasse 7/A5-1, A-1150 Wien www.turck.at
Poland	TURCK sp.z.o.o. Wroclawska 115, PL-45-836 Opole www.turck.pl
Romania	Turck Automation Romania SRL Str. Siriului nr. 6-8, Sector 1, RO-014354 Bucuresti www.turck.ro
Russian Federation	TURCK RUS OOO 2-nd Pryadilnaya Street, 1, 105037 Moscow www.turck.ru
Sweden	Turck Sweden Office Fabriksstråket 9, 433 76 Jonsered www.turck.se
Singapore	TURCK BANNER Singapore Pte. Ltd. 25 International Business Park, #04-75/77 (West Wing) German Centre, 609916 Singapore www.turckbanner.sg
South Africa	Turck Banner (Pty) Ltd Boeing Road East, Bedfordview, ZA-2007 Johannesburg www.turckbanner.co.za
Czech Republic	TURCK s.r.o. Na Brne 2065, CZ-500 06 Hradec Králové www.turck.cz
Turkey	Turck Otomasyon Ticaret Limited Sirketi Inönü mah. Kayisdagi c., Yesil Konak Evleri No: 178, A Blok D:4, 34755 Kadiköy/ Istanbul www.turck.com.tr
Hungary	TURCK Hungary kft. Árpád fejedelem útja 26-28., Óbuda Gate, 2. em., H-1023 Budapest www.turck.hu
USA	Turck Inc. 3000 Campus Drive, USA-MN 55441 Minneapolis www.turck.us

TURCK

Over 30 subsidiaries and over
60 representations worldwide!

D102213 | 2022/03



www.turck.com