

TURCK

Industrial
Automation

piconet[®] -

**USER MANUAL
I/O MODULES**



All brand and product names are trademarks or registered trademarks of the owner concerned.

Edition 06/2013

© Hans Turck GmbH & Co. KG, Mülheim an der Ruhr

All rights reserved, including those of the translation.

No part of this manual may be reproduced in any form (printed, photocopy, microfilm or any other process) or processed, duplicated or distributed by means of electronic systems without written permission of Hans Turck GmbH & Co. KG, Mülheim an der Ruhr.

Subject to alterations without notice.

Warning!

Dangerous electrical voltage!

Before commencing the installation

- Disconnect the power supply of the device.
- Ensure that devices cannot be accidentally restarted.
- Verify isolation from the supply.
- Earth and short circuit.
- Cover or enclose neighbouring units that are live.
- Follow the engineering instructions (AWA) of the device concerned.
- Only suitably qualified personnel in accordance with EN 50 110-1/-2 (VDE 0 105 Part 100) may work on this device/system.
- Before installation and before touching the device ensure that you are free of electrostatic charge.
- The functional earth (FE) must be connected to the protective earth (PE) or to the potential equalisation. The system installer is responsible for implementing this connection.
- Connecting cables and signal lines should be installed so that inductive or capacitive interference do not impair the automation functions.
- Install automation devices and related operating elements in such a way that they are well protected against unintentional operation.
- Suitable safety hardware and software measures should be implemented for the I/O interface so that a line or wire breakage on the signal side does not result in undefined states in the automation devices.
- Ensure a reliable electrical isolation of the low voltage for the 24 volt supply. Only use power supply units complying with IEC 60 364-4-41 (VDE 0 100 Part 410) or HD 384.4.41 S2.
- Deviations of the mains voltage from the rated value must not exceed the tolerance limits given in the specifications, otherwise this may cause malfunction and dangerous operation.

- Emergency stop devices complying with IEC/EN 60 204-1 must be effective in all operating modes of the automation devices. Unlatching the emergency-stop devices must not cause restart.
- Devices that are designed for mounting in housings or control cabinets must only be operated and controlled after they have been installed with the housing closed. Desktop or portable units must only be operated and controlled in enclosed housings.
- Measures should be taken to ensure the proper restart of programs interrupted after a voltage dip or failure. This should not cause dangerous operating states even for a short time. If necessary, emergency-stop devices should be implemented.
- Wherever faults in the automation system may cause damage to persons or property, external measures must be implemented to ensure a safe operating state in the event of a fault or malfunction (for example, by means of separate limit switches, mechanical interlocks etc.).
- The electrical installation must be carried out in accordance with the relevant regulations (e. g. with regard to cable cross sections, fuses, PE).
- All work relating to transport, installation, commissioning and maintenance must only be carried out by qualified personnel. (IEC 60 364 and HD 384 and national work safety regulations).
- All shrouds and doors must be kept closed during operation.

Table of Contents

How to work with this manual

Introduction	0-2
Correct usage to the intended purpose	0-2
Projecting guidelines/Product installation	0-2
Meaning of the symbols used	0-3
Release status and versions	0-4
Documentation	0-4
Firmware and hardware status	0-4
List of Revisions	0-6

1 The *piconet*[®] system

System overview	1-2
<i>piconet</i> [®] – Coupling and extension modules	1-4
IP-Link – modular extension network	1-4
Stand-alone modules	1-7

2 IP-Link

General description	2-2
Construction and Topology	2-3
Cycle time IP-Link	2-5
Technical data	2-8
IP-link connector	2-10
Trouble shooting in case of problems with the IP-Link	2-16

3 Register communication

General description	3-2
General register description	3-3
Register R0-R7	3-3
Register R8-R15	3-4
Register R16-R30	3-6
Register R31-R47	3-6
Register R33-R47	3-7
Register R47-R63	3-7
Example of register communication	3-8
Control byte	3-8
Read-out of the module type	3-11

Table of Contents

4 General technical information

Technical data	4-2
Supply voltage	4-4
Galvanic isolation	4-5
Incoming line and power supply	4-6
Power loss of power cable	4-8
Start-up performance of the <i>piconet</i> [®] modules.....	4-9
Dimension drawings.....	4-10

5 Diagnostic LEDs for local errors

Error diagnostics via LEDs	5-2
Flash codes	5-2
Local errors of a coupling module (SxxL-0404D-xxxx)	5-3
Local errors of an extension module	5-5

6 IP-Link coupling modules

Type overview	6-2
General description.....	6-3
Connection modes	6-3
I/O network with the IP-Link.....	6-3
Automatic input data mapping.....	6-4
SxxL-0404D-x00x , coupling module 4DI/4DO.....	6-5
Technical data	6-6
Wiring diagrams	6-7
Parameters	6-9
Diagnosis	6-9

7 Digital input modules

Type overview	7-2
Sxxx-0800D-x00x , 8-port digital input, filter 0.2 ms/3.0 ms	7-3
Technical data	7-4
Wiring diagrams	7-5
Parameters	7-6
Diagnosis.....	7-6

8 Digital output modules

Type overview	8-3
Sxxx-0008D-x006/ -x001 , 8-port digital output, 24 VDC, $I_{\max} = 0.5 \text{ A}$	8-4
Technical data	8-5
Wiring diagrams	8-5
Parameters	8-6
Diagnosis	8-6
Sxxx-0008D-x002/ -x003 , 8-port digital output, 24 VDC, $I_{\max} = 2 \text{ A}$	8-7
Technical data	8-9
Wiring diagrams	8-9
Parameters	8-10
Diagnosis	8-10
Sxxx-0008D-x004/ -x005 , 8-port digital output, 24 VDC, $I_{\max} = 2 \text{ A}$	8-11
Technical data	8-12
Wiring diagrams	8-13
Parameters	8-13
Diagnosis	8-13
Potential groups	8-14
SNNE-0016D-0001, 16 digital outputs 24 VDC, total current max. 4 A	8-15
Technical data	8-16
Wiring diagram	8-17
Meaning of the channel LEDs	8-17
Parameters	8-17
Diagnosis	8-17
Data mapping	8-18
Control and status byte	8-18
Register overview	8-21
Watchdog Feature (R32-R33).....	8-21
SNNE-0016D-0002, 16 digital outputs 24 VDC, total current max. 4 A	8-23
Technical data	8-23
The module's error behavior	8-23

9 Digital combined modules

Type overview	9-2
Sxxx-0404D-x003/-x004/-x001/-x002 , 4-port digital input; 4-port digital output	9-3
Technical data	9-5
Wiring diagrams	9-6
Parameters	9-8
Diagnosis	9-8

Table of Contents

Sxxx-0404D-x007/-x008/-x005/-x006,	
4-port digital input; 4-port digital output.....	9-9
Technical data	9-11
Wiring diagrams	9-12
Parameters	9-14
Diagnosis	9-14
Sxxx-0008D-x001, 8-port digital combined module	9-15
Technical data	9-17
Wiring diagrams	9-18
Parameters	9-19
Diagnosis	9-19
SNNE-0808D-0003, 8-port digital combined module with IP20 terminals .	9-20
Technical Data.....	9-21
Wiring diagrams	9-23
Parameters	9-24
Diagnosis	9-24

10 Analogue input modules

Type overview	10-4
Sxxx-40A-x005, 4-port analogue input module,	
-10/ 0 to +10 V	10-5
Technical data	10-7
Wiring diagrams	10-8
Supply voltage.....	10-9
Functions of the channel LEDs	10-10
Process data	10-10
Parameters	10-11
Diagnosis	10-11
Data mapping	10-11
Control and status byte.....	10-12
Register overview	10-15
Sxxx-40A-x007,	
4-port analogue input module, 0/(4) to 20 mA	10-23
Technical data	10-25
Wiring diagrams	10-26
Functions of the channel LEDs	10-27
Process data	10-27
Parameters	10-29
Diagnosis	10-29
Data mapping	10-29
Control and status byte.....	10-30

Register overview	10-33
Feature register (R32)	10-34

Sxxx-40A-x009,

4-port analogue input module for Pt100 (RTD)	10-37
Technical data	10-39
Wiring diagrams	10-40
Supply voltage	10-41
Functions of the channel LEDs	10-42
Process data	10-42
Parameters	10-43
Diagnosis	10-43
Data mapping	10-43
Control and status byte	10-44
Register overview	10-46
Feature register (R32)	10-48

Sxxx-40A-x004, 4-port analogue input module for thermoelements

Technical data	10-55
Wiring diagrams	10-56
Supply voltage	10-58
Functions of the channel LEDs	10-58
Function principle	10-59
Parameters	10-61
Diagnosis	10-61
Data mapping	10-61
Control and status byte	10-62
Register overview	10-65

11 Analogue output modules

Type overview	11-2
---------------------	------

Sxxx-04A-x007, 4-port analogue output module, ± 10 V

Technical data	11-5
Wiring diagrams	11-6
Functions of the channel LEDs	11-6
Process data	11-7
Parameters	11-8
Diagnosis	11-8
Data mapping	11-8
Control and status byte	11-9
Register overview	11-11

Table of Contents

Sxxx-04A-x009,

4-port analogue output module, 0/4 to 20 mA	11-15
Technical data	11-17
Wiring diagrams	11-18
Functions of the channel LEDs	11-18
Process data	11-19
Parameters	11-20
Diagnosis	11-20
Data mapping	11-20
Control and status byte	11-21

12 Technology modules

Type overview	12-4
---------------------	------

Sxxx-10S-x001,

1-channel incremental encoder interface	12-5
Technical data	12-7
Wiring diagram	12-8
Functions of the channel LEDs	12-8
Process data	12-9
Parameters	12-10
Diagnosis	12-10
Data mapping	12-10
Control and status byte	12-11
Register overview	12-16
Feature register (R32)	12-18

Sxxx-10S-x002,

1-channel RS232 interface	12-20
Technical data	12-22
Wiring diagram	12-23
Functions of the channel LEDs	12-23
Parameters	12-23
Diagnosis	12-24
Data mapping	12-24
Control and status byte	12-24
Register overview	12-30
Data byte register (R35)	12-35

Sxxx-10S-x004,

1-channel RS485/422 interface	12-36
Technical data	12-38
Wiring diagram	12-39
Functions of the channel LEDs	12-39
Parameters	12-40

Diagnosis	12-40
Data mapping	12-41
Control and status byte	12-41
Register overview	12-41
Sxxx-10S-x005,	
1-channel SSI interface	12-45
Technical data	12-47
Wiring diagram	12-48
Functions of the channel LEDs	12-48
Process data	12-48
Parameters	12-49
Diagnosis	12-49
Data mapping	12-49
Control and status byte	12-50
Register overview	12-53
Feature register (R32)	12-54
Baud rate register (R33)	12-55
Data length register (R34)	12-56
Sxxx-0002D-x002,	
2-channel pulse width output 24 VDC/2.5 A	12-57
Technical data	12-59
Wiring diagram	12-60
Functions of the channel LEDs	12-60
Operating modes	12-61
Pulse width ratio in the process data	12-70
Output power (Derating)	12-71
Parameters	12-74
Diagnosis	12-74
Data mapping	12-74
Control and status byte	12-75
Register overview of the PWM module	12-78
Feature register (R32)	12-80
Sxxx-0202D-x003,	
Up/down counter, 24 VDC, 100 kHz	12-81
Technical data	12-83
Wiring diagram	12-84
Meaning of the LEDs	12-85
Function principle	12-85
Parameters	12-87
Diagnosis	12-87
Data mapping	12-88
Control and status byte	12-88

Table of Contents

Register overview	12-92
Feature register (R32)	12-94
13 Third Party Products	
CPV valve terminal from the company Festo.....	13-2
General product description.....	13-2
Bus connection	13-2
Voltage supply.....	13-2
Support.....	13-2
Ordering.....	13-3
14 Appendix	
Module types	14-2
Nominal current consumption of the <i>piconet</i> [®] modules.....	14-3
Description of the module parameters.....	14-6
Module-independent user parameters.....	14-6
Digital coupling modules	14-7
Analogue input modules.....	14-8
Analogue output modules Sxxx-04A-000x	14-11
Technology modules	14-12
15 Glossary of terms	
16 Index	

How to work with this manual

Introduction	2
Correct usage to the intended purpose	2
Projecting guidelines/Product installation	2
Meaning of the symbols used	3
Release status and versions	4
Documentation	4
Firmware and hardware status	4
– Downward compatibility	4
List of Revisions	6

Introduction



Attention

It is indispensable to read this section because the safety in dealing with electrical equipment should not be left to chance.

This manual contains all information pertaining to safe and proper operation of the I/O modules of the TURCK product range *piconet*[®]. It was specially edited for qualified staff with the required specialized knowledge.

Correct usage to the intended purpose



Warning

The devices described in this manual may only be used in such applications described in the technical sections of the manual and only in conjunction with certified external devices and components.

Correct and safe operation of the devices relies on appropriate transport and storage, correct set-up and installation as well as careful operation and maintenance.

Projecting guidelines/Product installation



Warning

It is indispensable to observe the applicable safety and accident prevention regulations of the specific application.

Meaning of the symbols used



Warning

This sign is placed next to a warning indicating the presence of a hazard. This can relate to personal injury as well as to system damage (hardware and software).

The user should interpret this symbol as follows: exercise extreme caution.



Attention

This sign is placed next to a warning indicating a potential hazard. This can relate to personal injury as well as to system (hardware and software) and equipment damage.



Note

This sign is located next to general hints providing important information on individual or stepwise work procedures.

These hints may facilitate work and possibly help to avoid excess work resulting from faulty proceedings.

Release status and versions

Documentation

This documentation pertains to the hardware and firmware status at the time of editing this manual. The features of the *piconet*[®] systems are continuously developed and improved.

Changes in the documentation can be taken from Modification index of this manual.

Firmware and hardware status

Downward compatibility

The modules of the *piconet*[®] series are downward compatible. Older module cannot, however, feature the same characteristics than newer module versions. However, existing characteristics have been retained so that older modules can always be replaced with new ones.

The documentation describes the differences between the modules.

The firmware and hardware status of the *piconet*[®] modules can be taken from the version number printed on the side of the module. The version number can be identified by the prefix "D".

*Table 1:
Firmware and
hardware status*

Indication on module	Explanation	Example
D. kkjjxyzu		D.22011501
kk	Calendar week	Calendar week 22
jj	Year	of the year 2001
x	Firmware bus board	Firmware bus, version 1
y	Hardware bus board	Hardware, version 5
z	Firmware I/O board	Firmware I/O, 0 (no firmware needed for this board)
u	Hardware I/O board	Hardware I/O, version 1

List of Revisions

In comparison to the previous manual edition, the following changes/ revisions have been made:

<i>Table 2: List of revisions</i>	Chapter	Subject/ Description	new	changed
	2	„IP-link connector“, page 2-10		X



Note

The publication of this manual renders all previous editions invalid.

1 The *piconet*[®] system

System overview	2
<i>piconet</i> [®] – Coupling and extension modules	4
IP-Link – modular extension network	4
– Extension modules	6
– Maximum system expansion of the IP-Link	6
Stand-alone modules	7
– Combined modules	7

System overview

piconet[®], the "smallest" bus system within the TURCK programme, offers I/O modules with dimensions of only 1210/175/126 x 30 x 26,5 mm, ideally suited for application in serial machine engineering:

- the coupling modules as the interface between the fieldbus and the *piconet*[®] fibre-optic network (see Page 1-4),
- the extension modules connected to the coupling module (see Page 1-4) as well as
- the stand-alone modules for direct connection to the fieldbus (see Page 1-7).

All connections are screw connections and feature protection degree IP67.

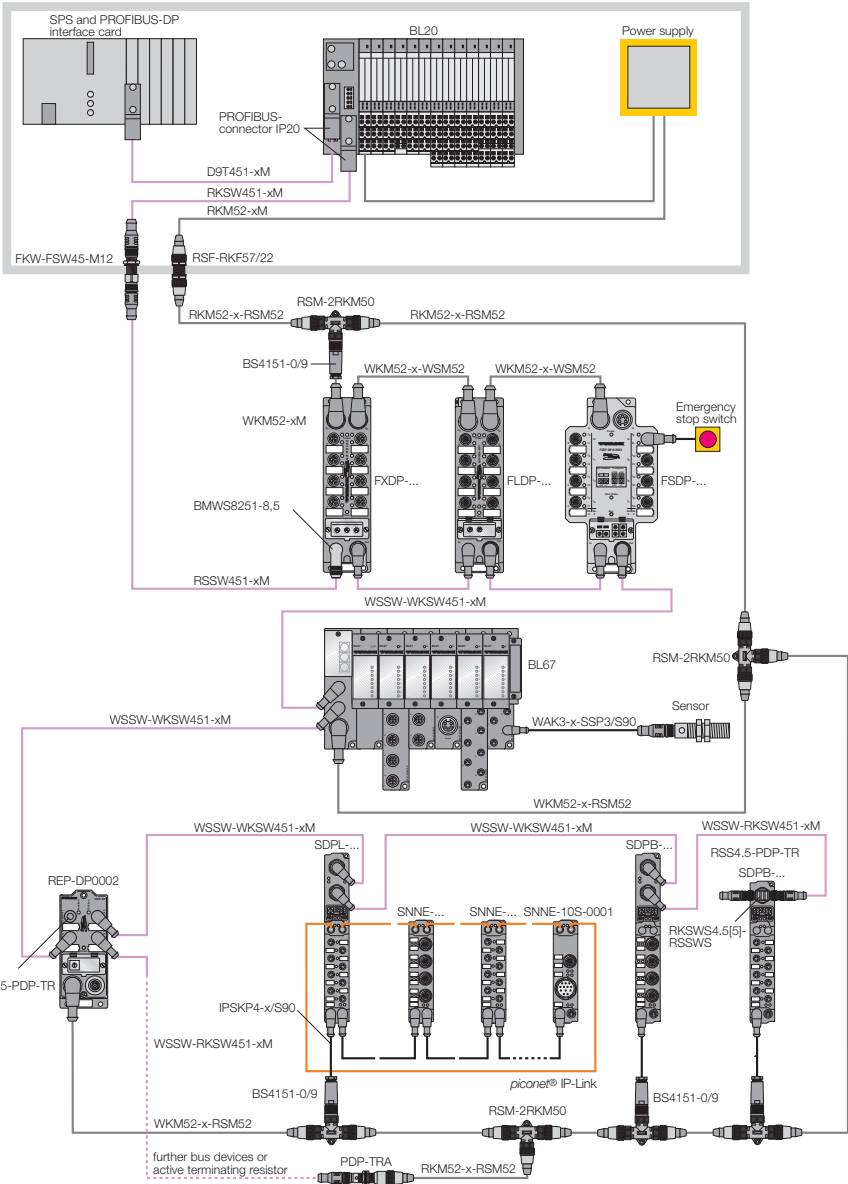

The **coupling modules** and the **stand-alone modules** are connected directly to the respective fieldbus.

Up to 120 I/O **extension modules** can be interconnected via the **IP-Link**, an extremely reliable internal bus based on fibre-optic transmission, and integrated into the higher level fieldbus as a single unit. Thus the user can determine any kind of I/O configuration that matches his application.

The **combined I/O modules** feature 16 channels (8 inputs and 8 outputs) and can be optimally adapted to all applications.

piconet[®] – Coupling and extension modules

The coupling module is equipped with two bus connections:

- via the fieldbus connection to the higher-level control, e. g. via the PROFIBUS-DP
- via the *piconet*[®] fibre-optic subnet for connection of extension modules.



Note

Coupling modules with the type code SxxL-xxxx-100x are equipped with an integrated T piece. This ensures even more space-saving installation of the modules.

IP-Link – modular extension network

The coupling module detects the I/O data of the connected extension modules via the interference immune and fast (2 Mbps) IP-Link network.

The IP-Link is a fibre-optic cable with a transmission rate of 2 Mbps. It transfers 1000 binary I/O data in approx. 1 ms quickly and reliably - if smaller assemblies are concerned, the transmission rate increases accordingly. Due to the high user data through-put it is guaranteed, that the connection via IP-Link does not affect the fieldbus performance perceivably.

Inexpensive connectors in protection degree IP67 have been developed for fast and simple field-assembly of the IP-Link cables. Connections do not require the use of any special tool and are established quickly and conveniently. IP-Link cables are also available with integral connectors.

Output groups can be turned off individually since the output

voltage is fed separately. Further it is easily possible to work with various potentials within an expansion ring because IP-Link is inherently equipped with optimum potential isolation.



Note

A detailed description of the fibre-optic system IP-Link can be taken from Chapter 2 of this manual.

Extension modules

Just like stand-alone modules, extension modules also cover the entire spectrum of I/O signals and may be mounted up to 15 m away from each other. They are particularly small and thus provide an especially cost-effective I/O solution in a high degree of protection. The digital inputs and outputs are connected via threaded M8 and M12 connectors. Analogue signal types feature M12 connections. The threaded connectors have a high tensile strength.



Note

The maximum distance between the modules is limited to 15 m max. due to the maximum admissible length of the fibre-optic cables.

Maximum system expansion of the IP-Link

Up to 120 extension modules can be connected to a coupling module. The length of the fibre-optic cable between two modules and thus the distance from module to module may not exceed 15 m.

The first four digital inputs and outputs can be directly connected to the coupling module. As with all digital *piconet*[®] modules, it is possible to choose between threaded M8 or M12 connectors. Further digital or analogue signals are integrated via the extension modules.

Figure 1:
Modular
extension network

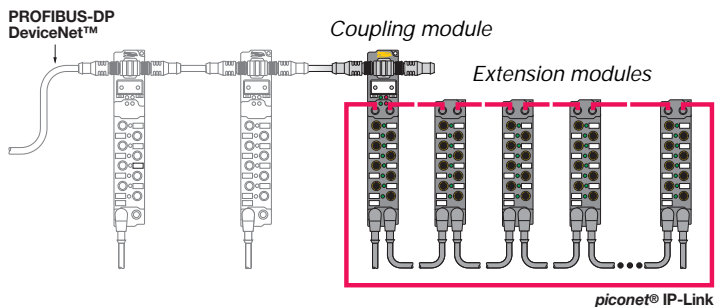

Stand-alone modules

piconet[®] stand-alone modules connect each *piconet*[®] I/O module directly to the fieldbus. Thus a 100% transparent transmission is ensured.



Note

Stand-alone modules with the type code SxxB-xxxx-100x are equipped with an integrated T piece. This ensures even more space-saving installation of the modules.

The module variety ranges from standardised digital industrial signals to analogue input/output modules.

For temperature monitoring there are thermoelement and resistance temperature detection modules available.

The compact robust housing with fully encapsulated electronics allows usage directly on the machine.

Combined modules

In order to obtain the highest flexibility, novel 16-channel digital combined I/O modules have been developed. The module channels can be used either as inputs or outputs. The separate circuitry ensures the isolated supply of the inputs and outputs. These combined modules enable precise modular construction of the system. The modules are powered via an M8 connector.

2 IP-Link

General description	2
Construction and Topology.....	3
– Construction of a ring	3
– Construction of a line structure	4
Cycle time IP-Link	5
Technical data	8
– General guidelines on the installation of IP-Link cables	8
– IP-Link network	8
– IP-Link cables	9
IP-link connector	10
– Preparation of the IP-link connector	10
– Assembly of the IP-link connector	11
– Surface treatment	12
– Disassembly of the IP-link connector	13
– Examples of pre-moulded connectors	14
Trouble shooting in case of problems with the IP-Link.....	16

General description

IP-Link is the sub-bus system of the *piconet*[®] system. The topology is a ring structure. The IP-Link master is incorporated in the coupling module. The extension modules are slaves. Up to 120 extension modules may be connected. Each module in the IP-Link reproduces the bus protocol. The spacing between two extension modules (IP-out > IP-in) may not exceed 15 m. During planning and installation of the extension modules, please observe that the fibre-optic cables must form a ring structure.

Construction and Topology

i **Note**

If a coupling module is to be used without extension modules, then the IP-Link connections must be bridged.

Construction of a ring

The first and last extension module may not be more than 15 m away from the coupling module.

Figure 2:
Ring structure of
the IP-Link

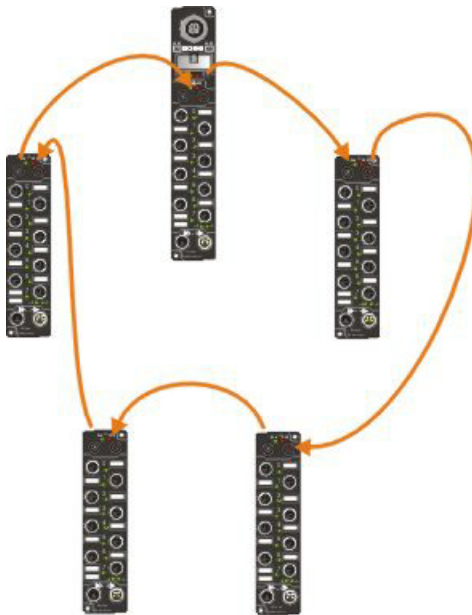

Construction of a line structure

If the distance between the last mounted extension module and the IP-Link master, i.e. the coupling module, is too long, then a line structure can be constructed with the IP-Link system. In this case, only every second extension module is connected during interconnection via the fibre-optic cable.



Attention

The length of a fibre-optic cable may never exceed 15 m.

For example:

You have 4 extension modules ($4 \times 15 \text{ m} = 60 \text{ m}$). Since only every second extension module is connected to the cable leading to the coupling module, ($15 \text{ m} + 15 \text{ m} = 30 \text{ m}$ line length), then the last extension module may have a maximum distance of 30 m from the coupling module. This means that in this case, in comparison to an arrangement of the modules in the ring, double the max. distance between coupling module and the last extension module is admissible.

Figure 3:
Line structure
of the IP-Link

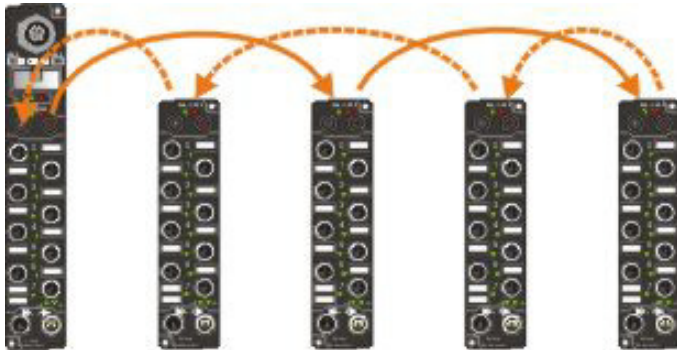

Note

The more modules are interconnected in this way, the higher the maximum admissible distance between coupling module and last extension module.

Cycle time IP-Link

Following *piconet*[®] modules with IP-Link connection are available:

- 1 Coupling module with IP-Link master for various fieldbuses:
 - SxxL-0404D-xxxx
- 2 Digital extension modules
 - SNNE-xxxx-xxxx (except those modules mentioned under 3)
- 3 Extension modules with interrupt operation
 - SNNE-0202D-x003,
 - SNNE-0002D-x00x,
 - SNNE-40A-x009,
 - SNNE-40A-x004
 - SNNE-10S-x00x
 - SNNE-0016D-0001
 - CPV-Ventilinseln
- 4 Extension modules with polling operation
 - SNNE-40A-x005
 - SNNE-40A-x007
 - SNNE-04A-x00x

The IP-Link cycle time of these modules may be increased because the response time in polling operation depends on the internal cycle of the extension module. This results in a minimum and maximum cycle time.



Note

For cycle time calculations it is of no importance whether input or output modules are concerned.

The internal processing time until the data are available for the higher level fieldbus is negligible.

$$\begin{aligned}
 T_{\min} = & \text{Coupling module base time} \\
 & + \text{No. of digital extensions} \times \text{DI time} \\
 & + \text{ROUND OFF} \\
 & \quad (\text{No. of all analogue extensions}/16) \times \text{AM base time} \\
 & + \text{No. of all analogue digital extensions} \times \text{AM time}
 \end{aligned}$$

$$\begin{aligned}
T_{\max.} = & \text{coupling module base time} \\
& + \text{coupling module jitter time} \\
& + \text{No. of digital extensions} \times \text{DI time} \\
& + \text{ROUND OFF} \\
& \quad (\text{No. of all analogue extensions}/16) \times \text{AM base time} \\
& + \text{No. of all analogue digital extensions} \times \text{AM time} \\
& + \text{ROUND OFF} \\
& \quad (\text{No. of analogue polling extensions}/16) \\
& \quad \times \text{AM jitter time}
\end{aligned}$$

with:

coupling module base time	=	300 μ s
coupling module jitter time	=	50 μ s
DI time	=	15 μ s
AM base time	=	800 μ s
AM time	=	175 μ s
AM jitter time	=	1000 μ s

For example:

- 1 coupling module (SDPL-0404D-xxxx)
- + 3 SNNE-0800D-0007
- + 2 SNNE-10S-0001
- + 1 SNNE-0002D-0002
- + 2 SNNE-40A-0005
- + 1 SNNE-04A-0007

- No. of digital extensions = 3
- No. of all analogue digital extensions = 6
- No. of analogue polling extensions = 3

$$\begin{aligned}
 T_{\min} &= 300 \mu\text{s} \\
 &+ 3 \times 15 \mu\text{s} \\
 &+ \text{ROUND-OFF}(6/6) \times 800 \mu\text{s} \\
 &+ 6 \times 175 \mu\text{s} \\
 &= 2195 \mu\text{s} = \underline{\underline{2.2 \text{ ms}}}
 \end{aligned}$$

$$\begin{aligned}
 T_{\max} &= 300 \mu\text{s} \\
 &+ 50 \mu\text{s} \\
 &+ \text{ROUND-OFF}(6/6) \times 800 \mu\text{s} \\
 &+ 6 \times 175 \mu\text{s} \\
 &+ \text{ROUND-OFF}(3/16) \times 1000 \mu\text{s} \\
 &= 3245 \mu\text{s} = \underline{\underline{3.3 \text{ ms}}}
 \end{aligned}$$

Technical data

General guidelines on the installation of IP-Link cables



Note

The installation instructions for fibre-optic cables must be observed. Take more care when installing fibre-optic cables than when using copper cables.



Attention

When installing the IP-Link cable, the minimum bend radius of 50 mm (static) and 55 mm (dynamic) must be observed!



Note

When routing cables in conduits, loop forming must be avoided. Subsequent modification of the installation could cause the loops to contract, while the minimum bending radius could thus be possibly under-ranged unnoticed.

IP-Link network

Table 3:
Technical data
IP-Link

baud rate	2 Mbps
Number of nodes	120
Length between two stations	15 m
Cable	– Plastic fibre-optics 1000 µm – 1-core, PU jacket with Kevlar fibre diameter 5.5 mm
IP-link connector	only SFOC permitted
Connector extraction force	20 N - 30 N

IP-Link cables

Table 4:
Technical data of
IP-Link cables

Outer diameter	5,5 mm
Nominal value	
Material	
optical fibre	PMA plastic fibre, Ø 1.0 mm
Fibre-optic sheathing	PE, color black, Ø 2.2 mm
Outer jacket	PU with approx. 1.4 mm wall thickness, color orange, Ø 5,5 ± 0,2 mm
Transmission characteristics	
Attenuation at 650 nm	typ. 170 up to 180 dB/km, max. 200 dB/km
Mechanical Features	
Bending radius, static	min. 50 mm
Bending radius, dynamic	min. 55 mm
Tensile strength (DIN VDE 0888 part 100, Verf.501)	
permanent	100 N
short-term	400 N
Temperature	- 20 to + 70 °C
Weight/ Nominal value	25 kg/km
Alternating bending resistance (DIN VDE 0888 part 100V Verf.509)	2 × 10 ⁶ cycles
Chemical characteristics	<ul style="list-style-type: none"> - Very good resistance against oil, fat, acids, alkalis - Long-term installation in water not admissible

IP-link connector

The IP-Link connector is a field-wireable fibre-optic male connector and provide an IP67 rated plug-in connection in combination with the female connector of the respective coupling or extension module.

Preparation of the IP-link connector

Figure 4:
IP-link connector
(Exploded view)

- A fibre-optic
- B outer jacket
- C Kevlar fibre
- D fibre jacket
- E fibre core
- F locking cap
- G O-ring
- H sleeve
- I connector housing

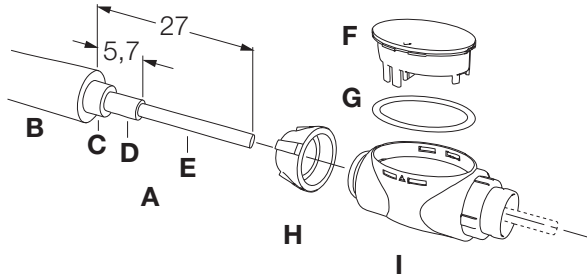

- 1 Strip cable jacket according to indicated lengths of outer and fibre jacket

ATTENTION:

The fibre core should not be damaged!

- 2 Cut the Kevlar fibre to the same length of the outer jacket.

ATTENTION:

In order to reach maximum clamping force outer and fibre jacket have to be free of deformation (grooves, etc.) as well as of grease, oil and lubricant.

Assembly of the IP-link connector

Figure 5:
Mounting the
connector

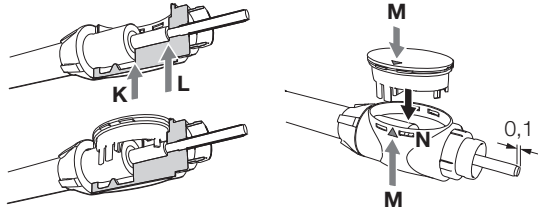

- 1 Pull the sleeve over the outer jacket and the O-ring over the locking cap.
- 2 Insert the prepared optic fiber in the connector housing until outer jacket hooks on **L** and fibre jacket hooks on **K** simultaneously.
- 3 Align the connector housing as required in order to prevent cable distort.
- 4 Pull the sleeve over the connector housing until it radially latches
- 5 Press the locking cap into the connector housing until all 4 nibs latch. This operation can be implemented without tools or with corresponding pliers. Keep locking cap in correct mounting position **M**.
The correct mounting of the O-ring can be checked with the latching holes **N**.

Surface treatment

Figure 6:
Surface treatment

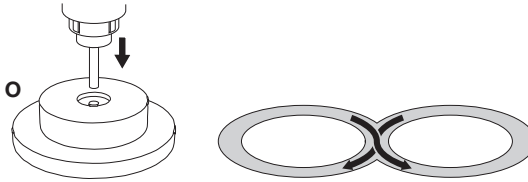

- 1** Treat the fibre core with the grinding gauge **O** up to the final dimension and intended quality.
For this purpose take sand paper of grain size 600, and work on a smooth surface.
- 2** Insert the mounted connector in the grinding gauge and treat the surface with a circular movement.
- 3** Remove grinding dust with a clean lint-free cloth.
- 4** Check the quality of the grinded surface.
The surface has to be smooth and free of scratches, grooves and splinters.

Disassembly of the IP-link connector

Figure 7:
Disassembly of
the IP-link con-
nector

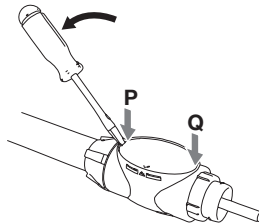

- 1 Apply appropriate tool at cut-out **P** or **Q**.
- 2 Lift out the locking cap from the closed connector housing.
ATTENTION:
Damaged or deformed components should not be applied again after disassembly.
- 3 Prepare fibre-optic after disassembly according to „Preparation of the IP-link connector“, Page 2-10 again.

Examples of pre-moulded connectors

The photos were made using a pocket lamp with white light which shines into the other end of the optical fibre.

Correct:

The optical fibre slightly projects the surface and has been polished at right angles. There are no splinters etc. visible.

*Figure 8:
Correctly
assembled
connector*

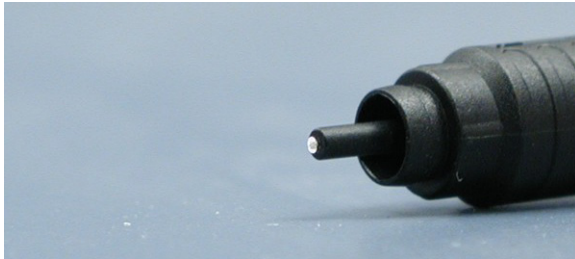

Wrong:

The fibre was cut off too short before the connector so that it splinters within the connector (dark section in the fibre centre). It must be cut off again.

*Figure 9:
Fibre-optic cable
too short and
splintered*

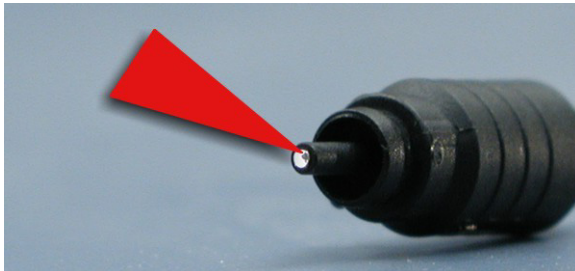

Wrong:

The fibre-optic cable was cut off too short right from the beginning. The fibre not even reaches into the connector end. It must be cut off again.

*Figure 10:
Fibre-optic cable
too short*

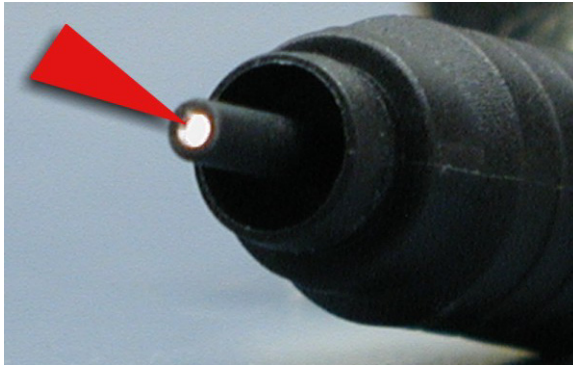
**Wrong:**

The fibre was polished correctly. It shows a clear, even light emission

But:

The fibre is too long and could thus damage the optical elements of the module during plug-in. Simply grind back the fibre a little more.

*Figure 11:
Fibre-optic cable
is too long*

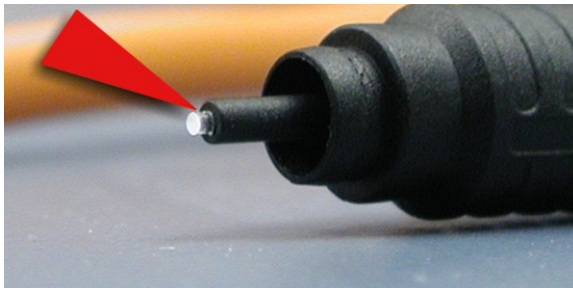

Trouble shooting in case of problems with the IP-Link

If the IP-Link error LED illuminates or flashes irregularly, there is no message transmission or the telegrams are faulty. The modules amplify every telegram but they cannot correct an error occurred once. The error must thus be traced backward from the last module to the first error-free module. The connection from this module to the next module is the source of error.

This error is usually due to IP-Link lines with too high damping. A possible cause could be the faulty assembly of cables and connectors.



Note

The most simple test is visual inspection: When held against a not too bright light source, the respective connector surface should provide a uniformly lightened image (check both sides).

In case of doubt, re-assemble the connector. Please take care not to grind the optical fibre too far back (see Page 2-14, „Examples of pre-moulded connectors“).



Note

During connector assembly please ensure that the specifications on insulation stripping are observed.

The assembled cable can be tested simply when connected between coupling and extension module. If the cable is correctly connected, there will be no faulty telegrams.

3 Register communication

General description	2
General register description.....	3
Register R0-R7	3
Register R8-R15	4
Register R16-R30	6
Register R31-R47	6
Register R33-R47	7
Register R47-R63	7
Example of register communication	8
Control byte.....	8
– Writing the password	9
Read-out of the module type	11

General description

The parameterisable *piconet*[®] modules have an almost identical data structure. The data area of the module is divided into words and contains 64 memory locations (registers).

The main module data and parameters can be read and written via these registers. In case of multichannel modules, each channel features this register structure.

Each module has, depending on the module type, a specific register assignment and number of registers used.

The following general register description contains the contents of the registers which are identical for all complex modules.



Note

The module-specific registers and their configuration can be taken from the respective module descriptions in the following chapters of this manual.

General register description

Complex modules have a processor of their own. They are thus capable of exchanging data bi-directionally directly with the higher level control. These modules will be referred to as intelligent modules in the following. These comprise the analogue modules and all other parameterisable modules.

The main features of the data structure of the intelligent modules are internally more or less identical. The data area of the module is divided into words and contains 64 memory locations. The main module data and parameters can be read and adjusted via this structure. Additional function call-ups with according parameters are possible.

Each logical channel of an intelligent module features such a structure (4-channel analogue modules thus possess 4 register sets).

This structure is divided into the following fields:

<i>Table 5: Register</i>	Areas	Register address
	Process variables	0-7
	Manufacturer parameters	8-16
	Type register	16-30
	User parameters	31-47
	Extended user area	48-63

Register R0-R7

In the internal RAM of the module: The process variables can be used in addition to the actual process image and are module-specific in their function.

■ **Register R0-R5**

These registers possess a module-type dependent function.

■ **Register R6**

Diagnostic register:

The diagnostic register can contain the following additional diagnostic information.

Contents:

■ **Register R7**

Command register:

- 1 High-Byte_Write = function parameter
- 2 Low-Byte_Write = function number
- 3 High-Byte_Read = function result
- 4 Low-Byte_Read = function number

Register R8-R15

(in the internal RAM of the module)

Type and system parameters are programmed by the manufacturer and can only be read and not modified by the user.

■ **Register R8**

Module type:

The module type in register R8 is needed for identification of the module.

■ **Register R9**

Software version x.y.:

The software version can only be read as ASCII character string.

■ **Register R10**

Data length:

R10 contains the number of multiplex shift registers and their length in bit. The coupling module recognises this structure.

■ **Register R11**

Signal channels:

Compared to R10, this register contains the number of the logically present channels. An existing shift register can thus, for instance, consist of several signal channels.

■ **Register R12**

Minimum data length:

The respective byte contains the minimal channel data length to be transferred. If the MSB is set, then the control / status byte is not obligatory for function of the module and is not transferred to the controller during module configuration. The information stands

- in the High Byte (with an output module)
- in the Low Byte (with an input module)

■ **Register R13**

Data type register:

Table 6:
Data type register

Data type register	Description
0x00	Module without valid data type
0x01	Byte array
0x02	Structure: 1 Byte, n Bytes
0x03	Word array
0x04	Structure: 1 Byte, n words
0x05	Double word array
0x06	Structure: 1 Byte, n double words
0x07	Structure: 1 byte, 1 double word
0x08	Structure: 1 byte, 1 double word
0x11	Byte array with variable logic channel length
0x12	Structure: 1 byte, n bytes with variable logical channel length (e.g. 60xx)
0x13	Byte array with variable logical channel length

Data type register	Description
0x14	Structure: 1 byte n words with variable logical channel length
0x15	Double word array with variable logical channel length
0x16	Structure: 1 byte n double words with variable logical channel length

■ **Register R14**

not used

■ **Register R15**

Alignment bits (RAM):

With the alignment bits the analogue module is assigned to a byte limit in the internal bus.

Register R16-R30

Manufacturer parameters, serial EEPROM:

The manufacturer parameters are specific for every module type. They are programmed by the manufacturer but can also be changed via the control sytem. The manufacturer parameters are stored in the serial EEPROM of the module and are retained also in the event of a power failure. These registers can only be changed after setting a code word in R31.

Register R31-R47

User parameters, serial EEPROM:

The user parameters are specific for every module type. The can be changed by the programmer. The user parameters are stored in the serial EEPROM of the module and are retained also in the event of a power failure. The user area is write-protected via a code word.

■ R31

Code word register in the RAM:

In order to change parameters in the user area, the code word **0x1235** must be registered here. If a different value is entered in this register, then the write-protection is activated. With in-active write protection the code word is returned upon reading of the register; with active write-protection the register is assigned to the value zero.

■ R32

Feature register:

This register defines the operating modes of the module. Thus it is possible to activate, for example, a user-specific scaling function for the analogue I/O modules.

Register R33-R47

Module-specific registers:

These registers depend on the module type.

Register R47-R63

Register extension for additional functions.

Example of register communication

Access to the registers of the *piconet*[®] modules is enabled via an upload of the register communication, a write or read command and the entry of the register number in the control byte of the respective module.

Control byte

The control byte is contained in the output image and can be read or written.

Table 7:
Control byte

Bit 7	Bit 6	Bit 5	Bit 4	Bit 3	Bit 2	Bit 1	Bit 0
REG	R/W						Register number

Table 8:
Description of the bits of the control byte

Bit	Name	Description
7	REG	1 Register communication activated: The first two user data bytes are not used for process data exchange, but written to or read from the register set of the <i>piconet</i> [®] module.
6	R/W	0 – Read: The register is to be read without being modified.
		1 – Write: The register is to be written.
5 to 0	Register number	Number of the register that is to be read or written. Up to 64 registers are addressable.

Status byte

Table 9:
Status byte

Bit 7	Bit 6	Bit 5	Bit 4	Bit 3	Bit 2	Bit 1	Bit 0
REG	R						Register number

Table 10:
Description of the bits of the control byte

Bit	Name	Description
7	REG	1 Acknowledgement register access
6	R/W	0 Read
5	Register number to 0	Number of the register that has been read or written.

Writing the password

In order to make adjustments to a *piconet*[®] module via register communication, it is first required to reset the write-protection of the register.

For this, the password **0x1235** is written to register 31 of the module. The command to write to the register and thus to enable register communication via entry of the password is given by the control byte of the module.

Table 11:
Writing the register 31 (control byte)

Bit 7	Bit 6	Bit 5	Bit 4	Bit 3	Bit 2	Bit 1	Bit 0
1	1	0	1	1	1	1	1

The data bytes of the output data map of the modules contain the values which are to be transferred to the respective registers.

The password 0x1235 is written to data bytes 0 and 1 of the according module. Data byte 0 presents the least significant byte and data byte 1 the most significant byte.



Note

In which section of the output data map of the module data bytes 0 and 1 are contained, depends on the type of fieldbus system used and thus of the data mapping of the modules.

For this please also read Chapter 4 of the bus-specific *piconet*[®] manuals.

In our example 0x12 is written to data byte 1 and 0x35 to data byte 0.

Table 12:
High byte 0x1235

Bit 7	Bit 6	Bit 5	Bit 4	Bit 3	Bit 2	Bit 1	Bit 0
0	0	0	1	0	0	1	0

Table 13:
Low byte 0x1235

Bit 7	Bit 6	Bit 5	Bit 4	Bit 3	Bit 2	Bit 1	Bit 0
0	0	1	1	0	1	0	1

Read-out of the module type

Register 8 of each *piconet*[®] module contains information on the module type.

The read command for register 8 is sent via the control byte to the module as follows:

<i>Table 14: Reading register 8</i>	Bit 7	Bit 6	Bit 5	Bit 4	Bit 3	Bit 2	Bit 1	Bit 0
	1	0	0	0	1	0	0	0

Bit 7 = 1 → Register communication activated

Bit 6 = 0 → Register is read

Bit 5
up to Bit 0 = 8 → Register number

Upon request the module type is indicated by the input data bytes, depending on the module and data mapping.

For example:

Counter module → read module type: 05DE hex = **1502**



Note

The annex of this manual contains a description of the module-specific coding.

4 General technical information

Technical data	2
Supply voltage	4
Galvanic isolation	5
– Digital modules	5
– Analogue modules	5
Incoming line and power supply	6
– General information	6
Power loss of power cable	8
Start-up performance of the <i>piconet</i>[®] modules.....	9
Dimension drawings	10

Technical data

Table 15:
General
technical data
piconet®

Material	PA6 (Polyamid), encapsulation compound: Polyurethane
Mounting	2 x through-holes Ø 3 mm
Contacts	CuZn, gold-plated
Connection of extension modules	
Stand-alone module	not extendable
Coupling module	max. 120 with a total of 128 bytes input and 128 bytes output data
Digital I/O signals	
Stand-alone module	according I/O version
Coupling module	max. 960 inputs and outputs
Analogue I/O signals	
Stand-alone module	according I/O version
Coupling module	max. 60 inputs and outputs
Configuration options	
Stand-alone module	via the control system (register communication or parameter data) or I/O-ASSISTANT
Coupling module	via the control system (register communication) or I/O-ASSISTANT
baud rate	automatic detection up to 12 Mbps

Voltage supply

Operating voltage U_B 24 VDC (-15 %/+20 %)

Load voltage U_L 24 VDC (-15 %/+20 %)

Connection Power supply via:
1 x 4-pole male M8 connector
Feed through:
1 x 4-pole female M8 connector

Exception:
Sxxx-0008D-x004 2 x 4-pole male M8 connectors
Sxxx-0008D-x005

Environmental
conditions

Operating temperature 0 °C to +55 °C

Storage temperature -25 °C to +85 °C

permissible relative humidity 5...100 % with condensation

Vibration proofness according to IEC 68, part 2-6 / IEC 68, part 2-27

EMC to EN 50082-2/IEC/EN 50081-2

Degree of protection IP65/66/67 (to EN 60529)

Dimensions (W x H x D)

Stand-alone modules/
Coupling modules 175 x 30 x 26.5 mm
(height up to upper edge of PB socket 30 mm, with bus tee height approx. 65 mm)

Extension modules 126 x 30 x 26.5 mm

XXL modules 210 x 30 x 26.5 mm

Weight

Stand-alone modules/
Coupling modules approx. 250 - 280 g, depending on module type

Extension modules approx. 120 - 200 g, depending on module type

Supply voltage

The power supply is connected via 4-pole M8 connectors on each module.

- Operating voltage U_B : 24 VDC (-15 %/+20 %)

The 24 VDC operating voltage U_B is used to power the fieldbus (termination), the processor logics, the inputs as well as the sensor level.

The operating voltage is galvanically isolated from the fieldbus component (ASIC).

- Load voltage U_L : 24 VDC (-15 %/+20 %)

Load voltage U_L powers the digital outputs. It can be fed separately. If the load voltage is turned off (e.g. in an emergency stop), both the fieldbus function and supply and the input function will be retained.

Generally, the modules are equipped with a 4-pole male and a 4-pole female M8 connector for voltage supply:

Figure 12:
Pin configuration
M8 male and M8
female connector



1 = 24 VDC U_B 1 = BN
2 = 24 VDC U_L 2 = WH
3 = GND 3 = BU
4 = GND 4 = BK

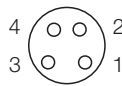

Exception for Sxxx-0008D-x004 und -x005



Note

With the digital output modules with a total current of $I_{\Sigma} = 12$ A, the supply voltage is provided by the male M8 connector. Feed through of the supply voltage is not possible. Three voltage circuits with 4 A each power the outputs.

Figure 13:
Pin configuration:
Voltage
supply for
Sxxx-0008D-x004
and -x005

Connector 1:



- 1 = 24 VDC U_B
- 2 = 24 VDC U_L , output 0...3
- 3 = GND
- 4 = GND

Connector 2:



- 1 = 24 VDC U_L , output 4...5
- 2 = 24 VDC U_L , output 6...7
- 3 = GND
- 4 = GND

Galvanic isolation

Digital modules

With the digital input/output modules, the ground potentials (GND) of supply and load voltage are connected.

Analogue modules

With the analogue input/output modules, these ground potentials are separated, in order to ensure galvanic isolation of the analogue signals from the operating voltage.



Attention

Should you use U_L for a feed-through arrangement, please observe during connection of a module without galvanic isolation between U_B and U_L (i.e. all digital modules) that galvanic isolation is neutralized through a feed-through of U_L .

Incoming line and power supply

General information

The max. load applied to each of the connection pins of a *piconet*[®] module may not exceed 4 A. This applies to both connection variants (M8 and M12).

These details must be observed:

- Current consumption of the modules
(see nominal current consumption of the modules in „Appendix“ of this manual)
- Current consumption of the sensors
- Current consumption of the actuators
- Cable lengths and power losses on the cables
(see power loss)
- If power is fed through, please ensure that the max. admissible current of 4 A per pin is not exceeded.

Examples

- 1 If all 8 outputs of a *piconet*[®] module with an 0.5 A output power rating are exposed to an output current load of 0.5 A simultaneously (simultaneity factor 1), the feed-through power line may not be used, because this could destroy the connection or the device.

- 2 If channels 0...3 are to be connected to a *piconet*[®] module with an output power rating of 2 A ($I_{\Sigma} = 12\text{ A}$), the load of 2 A may only be applied to 2 of the 4 channels.

Figure 14:
Load ratings of the
Connections

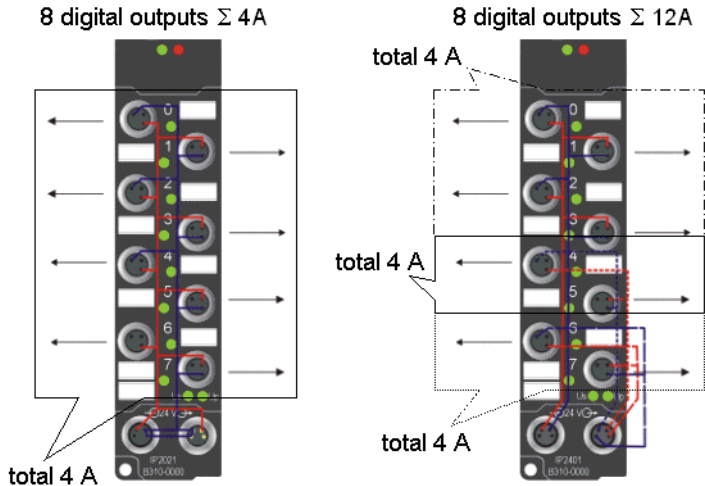

Power loss of power cable

When using the power cables IPS(W)KP4-xxxx, do not exceed the total length of 15 m at 4 A (with power feed-through).



Note

During connection please observe that with a nominal voltage of 24 VDC, the functionality of the modules cannot be ensured from a voltage drop of 6 V on.

Further please observe the voltage fluctuations of the power supply unit.

Example

At a load of 4 A, an 8 m power cable with 0.34 mm² has a voltage drop of 3.2 V.

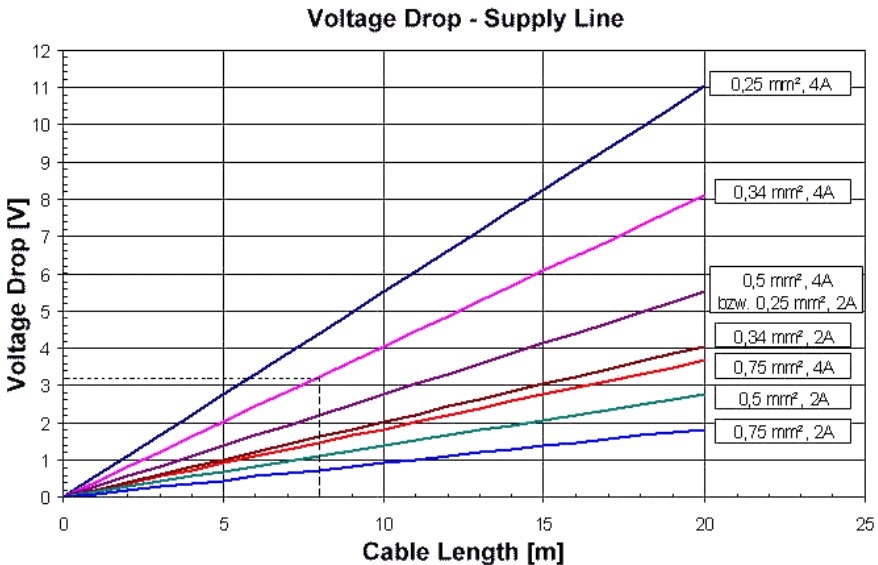

Start-up performance of the *piconet*® modules

Upon switch-on the module tests its status, configures the IP-Link (coupling modules) and then compiles a set-up list according to the detected extension modules.

During start-up of the modules, the I/O LEDs illuminate and flash. In an error-free condition, the I/O LEDs should stop flashing after 2-3 seconds. If an error has occurred, it depends on the type of error which LED starts flashing (see Chapter "Error treatment and diagnostics" in the bus-specific *piconet*® manual).

Figure 15:
Start-up
performance

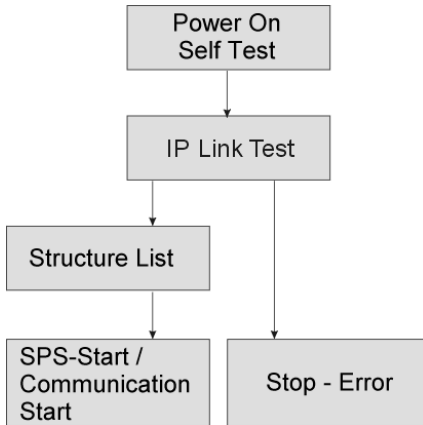

Dimension drawings

Figure 16:
Dimensions of the
piconet® modules

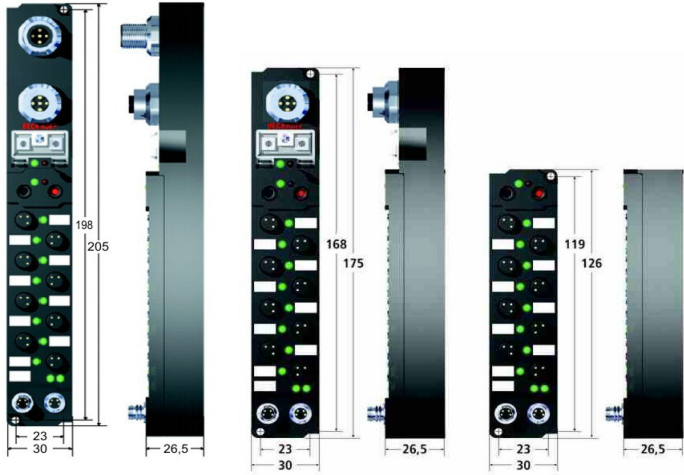

5 Diagnostic LEDs for local errors

Error diagnostics via LEDs	2
Flash codes	2
Local errors of a coupling module (SxxL-0404D-xxxx)	3
Local errors of an extension module	5

Error diagnostics via LEDs

With the *piconet*[®] system, one distinguishes between the following kind of errors:

- Fieldbus errors
- IP-Link errors or local module errors

Figure 17:
LEDs

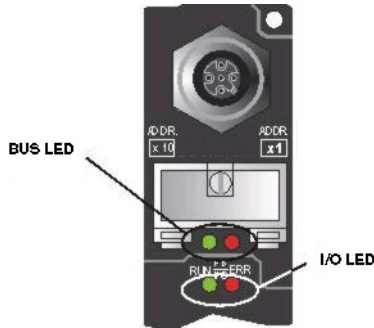

Flash codes

Table 16:
LED flash codes

Flash sequence	Meaning
Fast flashing	Start
first slow sequence	Error code
second slow sequence	Error argument 1
third slow sequence (optional)	Error argument 2 (with more than 20 extensions)

Figure 18:
Flash codes

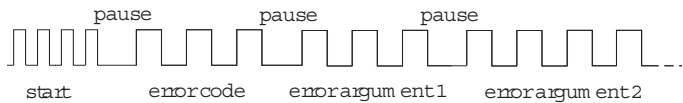

Local errors of a coupling module (SxxL-0404D-xxxx)

Local errors are errors of the *piconet*[®] module or the IP-Link.

Table 17:
Local errors of a
SxxL-0404D-xxx

	LED, LED green red		Error argument		Description	Remedy:	
	LED	LED	1	2			
A Counting begins with $n = 1$ with the last connected extension module against the direction of the fibre-optic cabling backwards in the direction of the coupling module.	OFF	OFF	-	-	no exchanging data	Module in synchronous mode → activate cyclic data	
	OFF	1	0	-	EEPROM check sum error	Set manufacturer settings	
	OFF	2	-	-	reserved	-	
	OFF	3	n	-	Wire-break detected C	Wire-break after extension module n A	
B With more than 20 extensions on the IP-Link the following applies: $n =$ stands for the tens, $m =$ stands for the ones of the "module number"		3	B	n	m	Wire-break detected C	Wire-breakage: behind the $(n\text{-module} * 10) + m\text{-module}$ A
	OFF	4	n	-	Too many faulty telegrams detected (more than 25 %)	Error localisation: in front of the extension module n – check fibre-optic cabling	
C The wire brak will be detected as long as the error occurs	OFF	5	n	-	Register access to complex modules failed	n-module check	
	OFF	11	n	-	Faulty operation of complex module	Replace n-module	

LED, green	LED red	Error code		Description	Remedy:
		Error argument			
		1	2		
OFF	12	n	-	More than 120 modules connected in IP-Link ring	Reduce no. of modules within IP-Link
OFF	13	n	-	n-module unknown	Firmware update required
ON	OFF	-	-	Module is exchanging data (no errors)	-

Local errors of an extension module

Table 18:
Local errors of a
SNNE-0404D-xxx

LED, green	LED red	Description
OFF	ON	No data are received via the IP-Link
OFF	flashes, flickers	Faulty IP-Link protocols are received (very bad data connection)
flashes, flickers	flashes, flickers	Faulty IP-Link protocols are received (bad data connection), → must not yet lead to an error
flashes, flickers	OFF	IP-Link protocols are received, no errors



Note

IP-Link errors can usually be attributed to inappropriate use of the fibre-optic cabling.

Faulty IP-Link protocols can be caused by:

- badly assembled IP-Link connectors
- IP-Link cables with increased damping (e.g. through bends or similar in the cable)
- a defect or contaminated emitter LED on the module prior to the faulty module
- defect or dirty receiver.

6 IP-Link coupling modules

Type overview	2
General description	3
Connection modes	3
I/O network with the IP-Link.....	3
Automatic input data mapping	4
SxxL-0404D-x00x, coupling module 4DI/4DO	5
Technical data	6
Wiring diagrams	7
Parameters	9
Diagnosis	9
– Diagnostics via LEDs	9
– Diagnostics via software	9

Type overview

<i>Table 19: Type overview of IP-Link Coupling modules</i>	SxxL-0404D-x00x	Description	Connection technology
	SxxL-0404D- x003 , Page 6-3	– 4 digital inputs, 24 V DC, filter 3.0 ms	M8
	SxxL-0404D- x004 , Page 6-3	– 4 digital outputs, 24 V DC; $I_{\max} = 0.5 \text{ A}$	M12

General description

The coupling modules transfer the I/O data of the digital and analogue sensors or actuators connected to the module to the fieldbus. They also collect the I/O data of the extension modules via the interference immune fibre-optic connection (IP-Link). These data are processed bus-specifically by the coupling modules and transferred to the respective fieldbus.

Connection modes

The IP-Link coupling module, SxxL-0404D-x00x, is equipped with two bus connections,

- via the fieldbus connection to the higher level control (e. g. PROFIBUS-DP, DeviceNet™)
- via the *piconet*[®] fibre-optic subnet for connection of extension modules.

In addition it is possible to connect 4 binary switches or sensors as well as 4 binary actuators directly to the coupling module.

I/O network with the IP-Link

Up to 120 extension modules can be connected to a coupling module. From the view of the fieldbus, the coupling module with all the connected extension modules is a single node with an according high number of I/O signals. Thus it can be regarded as an IP67 remote I/O network with a single fieldbus interface only.

Automatic input data mapping

The coupling module automatically detects the connected extension modules during the start-up phase and automatically maps the I/O data to the fieldbus process image. Configuration is thus not necessary.

SxxL-0404D-x00x, coupling module 4DI/4DO

These digital I/O modules combine 4 digital inputs with an input filter of 3 ms and 4 digital outputs in a single device.

The outputs are suited for load currents of 0.5 A. They are short-circuit and reverse-polarity protected.

The signal status can be indicated separately for each channel via LEDs.

The inputs are located on the upper half of the modules. With M8 connection technology modules, these are the upper four connectors (C0 to C3), and with the M12 technology modules the two upper connectors (C0, C1) with two inputs on one connector.

Figure 19:
SDPL-0404D-x003

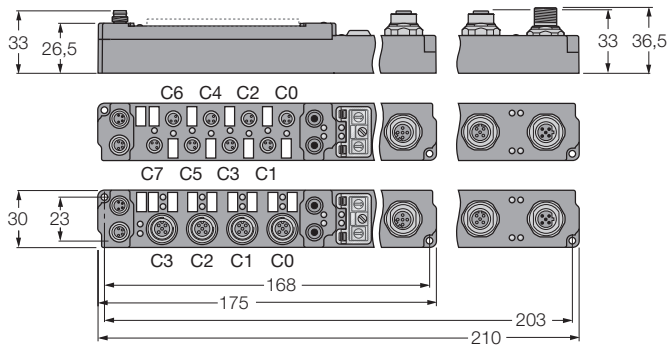

Technical data

Table 20:
Technical data

Designation	SxxL-0404D-x001, -x002, -x003, -x004
Voltage supply	
Operating voltage U_B	24 VDC (-15 %/+20 %)
Load voltage U_L	24 VDC (-15 %/+20 %)
Inputs	
Number of inputs	4, according to EN 61131-2
Input voltage	24 VDC (-15 %/+ 20 %)
Supply current	500 mA, short-circuit protected
Input filter	3.0 ms
Max. input current	< 7 mA
Switching point 0/1	-3... 5 V / 11...30 V, 6 mA input current (EN 61131-2, type 2)
Sensor supply	from operating voltage U_B , max. 0.5 A per module, common short-circuit protection
Outputs	
Number of outputs	4, according to EN 61131-2
Output voltage	24 VDC (-15 %/+ 20 %)
Output current per channel	max. 0.5 A per channel, each channel is short-circuit protected
Load type	ohmic, inductive, lamp load
Current consumption Load voltage	20 mA. typ.
Short-circuit current	typically 1.5 A (cyclic)

Switching frequency	500 Hz
Simultaneity factor	1
Bits in the process image	4 input or 4 output bits
Potential isolation	<ul style="list-style-type: none"> - Channels/Operating voltage: no - Between the channels: no - Operating voltage/fieldbus: yes

Wiring diagrams

Figure 20:
Connection to the
M8

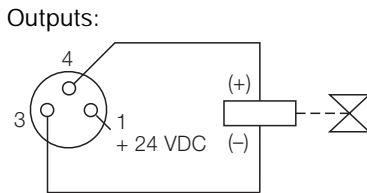
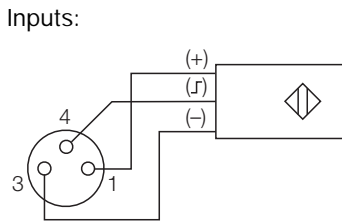
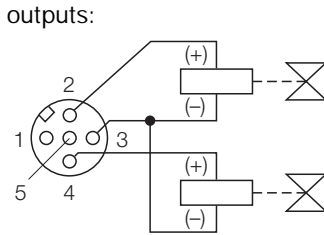
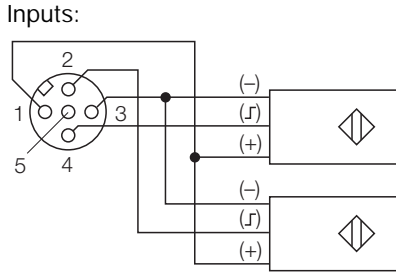

Figure 21:
Connection to the
M12



Parameters

Detailed information on fieldbus-dependent parameterisation of the modules is contained in the chapter "Parameters of the *piconet*[®] I/O modules" of the following manuals:

- Profibus-DP
German: „*piconet*[®] for PROFIBUS-DP“, D300775
English: „*piconet*[®] for PROFIBUS-DP“, D300776
- DeviceNet
Not yet published
- CANopen
Not yet published

Diagnosis

Diagnostics via LEDs

Please read the description of the diagnostic LEDs in the event of local errors of the coupling and extension modules in Chapter 5 of this manual: Fieldbus-specific diagnostic indications via LEDs are described in the chapter "Error treatment and diagnostics" of the above mentioned manuals.

Diagnostics via software

Detailed information on fieldbus-dependent diagnostics of the modules is contained in the chapter "Error treatment and diagnostics" of the above mentioned manuals.

7 Digital input modules

Type overview.....	2
Sxxx-0800D-x00x, 8-port digital input, filter 0.2 ms/3.0 ms	3
Technical data	4
Wiring diagrams	5
Parameters	6
Diagnosis	6
– Diagnostics via LEDs	6
– Diagnostics via software	6

Type overview

The device type Sxxx-0800D is designed for connection of 8 binary switches or sensors.

The devices come as stand-alone or extension modules and differ in their connection technology and input filter speed.

*Table 21:
Type overview
digital input
modules*

Sxxx-0800D-x00x	Description	Connection technology
Sxxx-0800D- x007 , Page 7-3	– 8 digital inputs, 24 VDC, filter 3.0 ms	M8
Sxxx-0800D- x004 , Page 7-3		M12
Sxxx-0800D- x008 , Page 7-3	– 8 digital inputs, 24 VDC, filter 0,2 ms	M8
Sxxx-0800D- x002 , Page 7-3		M12

Sxxx-0800D-x00x, 8-port digital input, filter 0.2 ms/3.0 ms

The digital input modules type Sxxx-0800D-x00x detect the binary control signals at the process level and transfer these to the higher level automation device. The signal status is indicated via LEDs.

The sensors are powered via the operating voltage U_B . The load voltage U_L connection is not needed by the input module, but can be used for optional power feed-through.

Figure 22:
SDPB-0800D-x00x
SNNE-0800D-x00x

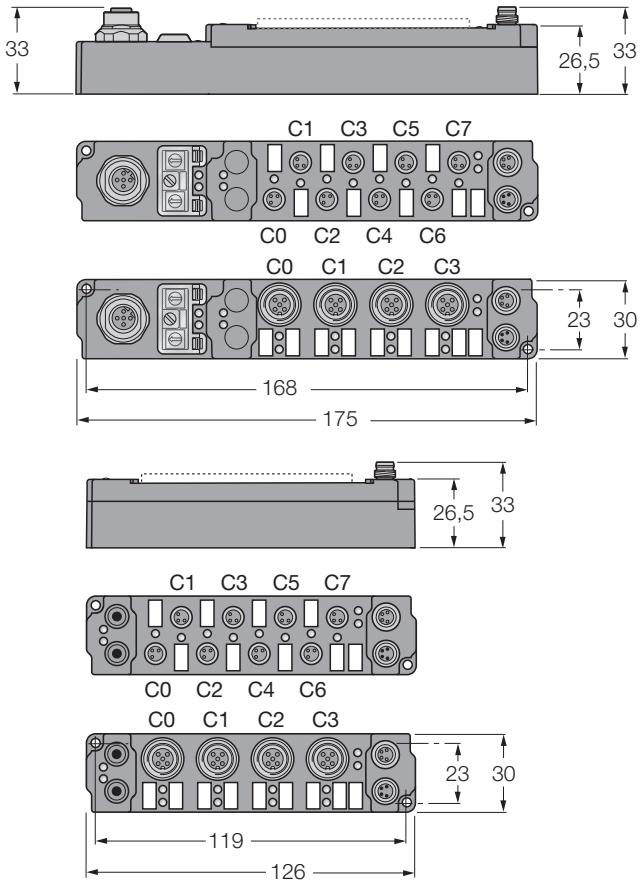

Technical data

Table 22:
Technical data

Designation	Sxxx-0800D-x007/ -x004 / -x008, / -x002
Voltage supply	
Operating voltage U_B	24 VDC (- 15 %/+ 20 %)
Load voltage U_L	24 VDC (- 15 %/+ 20 %)
Number of inputs	8, according to EN 61131-2
Input filter	
...x007/...x004	3.0 ms
...x008/...x002	0,2 ms
Input voltage	24 VDC (- 15 %/+ 20 %)
Signal voltage "0"	-3 V...5 V (EN 61131-2, Type 2)
Signal voltage "1"	11 V...30 V (EN 61131-2, Type 2)
Input current, typical	6 mA (EN 61131-2, Type 2)
Sensor supply	via operating voltage, max. 0.5 A per module, common short-circuit protection
Bits in the process image	8 input bits
Potential isolation	- Channels/Operating voltage: no - Between the channels: no - Operating voltage/fieldbus: yes

Wiring diagrams

Figure 23:
Connection to the
M8

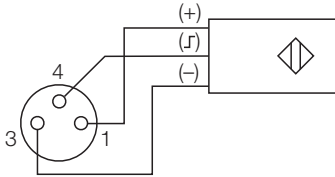
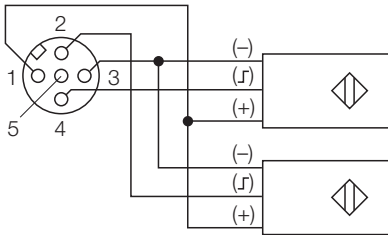

Figure 24:
Connection to the
M12



Parameters

Detailed information on fieldbus-dependent parameterisation of the modules is contained in the chapter "Parameters of the *piconet*[®] I/O modules" of the following manuals:

- Profibus-DP
German: „*piconet*[®] für PROFIBUS-DP“, D300775
English: „*piconet*[®] for PROFIBUS-DP“, D300776
- DeviceNet
Not yet published
- CANopen
Not yet published

Diagnosis

Diagnostics via LEDs

Please read the description of the diagnostic LEDs in the event of local errors of the coupling and extension modules in Chapter 5 of this manual: Fieldbus-specific diagnostic indications via LEDs are described in the chapter "Error treatment and diagnostics" of the above mentioned manuals.

Diagnostics via software

Detailed information on fieldbus-dependent diagnostics of the modules is contained in the chapter "Error treatment and diagnostics" of the above mentioned manuals.

8 Digital output modules

Type overview	3
Sxxx-0008D-x006/ -x001, 8-port digital output, 24 VDC,	
$I_{\max} = 0.5 \text{ A}$	4
Technical data	5
Wiring diagrams	5
Parameters	6
Diagnosis	6
– Diagnostics via LEDs	6
– Diagnostics via software	6
Sxxx-0008D-x002/ -x003, 8-port digital output, 24 VDC,	
$I_{\max} = 2 \text{ A}$	7
Technical data	9
Wiring diagrams	9
Parameters	10
Diagnosis	10
– Diagnostics via LEDs	10
– Diagnostics via software	10
Sxxx-0008D-x004/ -x005, 8-port digital output, 24 VDC,	
$I_{\max} = 2 \text{ A}$	11
Technical data	12
Wiring diagrams	13
Parameters	13
Diagnosis	13
– Diagnostics via LEDs	13
– Diagnostics via software	14
Potential groups	14
SNNE-0016D-0001, 16 digital outputs 24 VDC, total current	
max. 4 A	15
Technical data	16
Wiring diagram	17
Meaning of the channel LEDs	17
Parameters	17
Diagnosis	17
– Diagnostics via LEDs	17
– Diagnostics via software	18

Data mapping	18
Control and status byte	18
– Process data operation	18
– Register communication	20
Register overview	21
Watchdog Feature (R32-R33).....	21
SNNE-0016D-0002, 16 digital outputs 24 VDC, total current max. 4 A.....	23
Technical data	23
The module's error behavior	23

Type overview

The device type Sxxx-008D-x00x is designed for connection of 8 binary actuators. The devices come as stand-alone or extension modules and differ in their connection technology, max. admissible output current per channel and max. total current rating.

Table 23:
Type overview
digital output
modules

Sxxx-0008D-x00x	Description	Connection technology
Sxxx-0008D- x006 , page 8-4	– 8 digital outputs 24 VDC, $I_{\max} = 0.5 \text{ A}$	M8
Sxxx-0008D- x001 , page 8-4		M12
Sxxx-0008D- x002 , page 8-7	– 8 digital outputs 24 VDC, $I_{\max} = 2 \text{ A}$; ($I_{\Sigma} = 4 \text{ A}$)	M8
Sxxx-0008D- x003 , page 8-7		M12
Sxxx-0008D- x004 , page 8-11	– 8 digital outputs 24 VDC, $I_{\max} = 2 \text{ A}$; ($I_{\Sigma} = 12 \text{ A}$)	M8
Sxxx-0008D- x005 , page 8-11		M12

Sxxx-0008D-x006/ -x001, 8-port digital output, 24 VDC, $I_{max} = 0.5 A$

The digital output modules transfer the binary control signals of the automation device to the actuators at the process level. The 8 outputs process load currents of up to 0.5 A and indicate their signal status via LEDs.

The outputs are short-circuit and reverse-polarity protected.

Figure 25:
SDPB-0008D-x00x
SNNE-0008D-000x

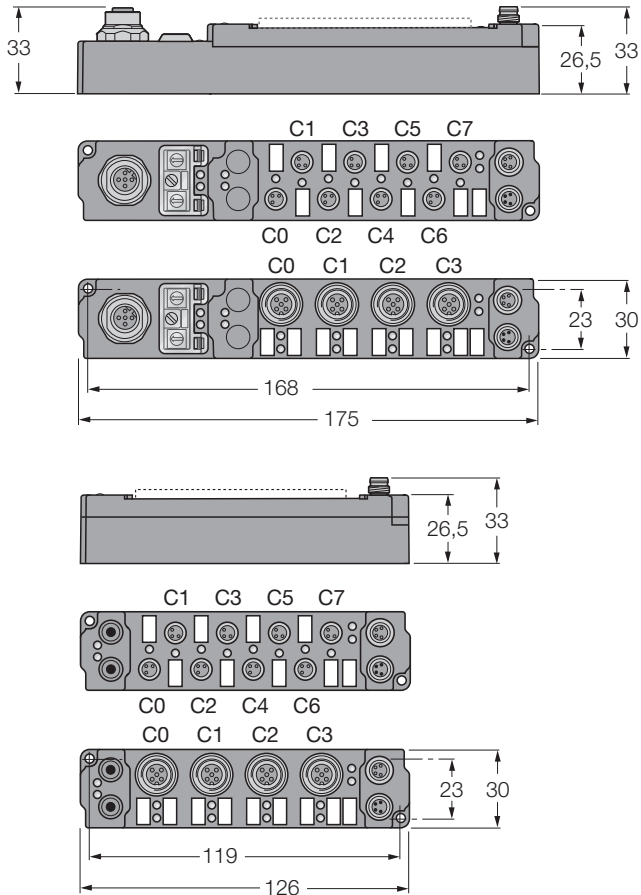

Technical data

Table 24:
 Technical data

Designation	Sxxx-0008D-x006/ -x001
Voltage supply	
Operating voltage U_B	24 VDC (- 15 %/+ 20 %)
Load voltage U_L	24 VDC (- 15 %/+ 20 %)
Number of outputs	8, according to EN 61131-2
Load type	ohmic, inductive, lamp load
Output voltage	24 VDC (- 15 %/+ 20 %)
Output current per channel	max. 0.5 A, each channel is short-circuit protected
Short-circuit current	typically 1.5 A
Current consumption Load voltage	20 mA. typ./per channel
Switching frequency	500 Hz
Simultaneity factor	1
Bits in the process image	8 bits output data

Wiring diagrams

Figure 26:
 Connection to M8

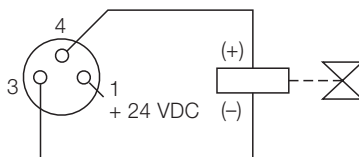
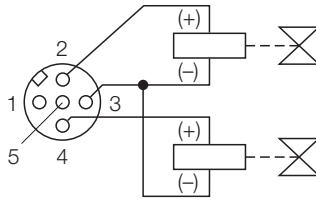

Figure 27:
Connection to the
M12



Parameters

Detailed information on fieldbus-dependent parameterization of the modules is contained in the chapter "Parameters of the *piconet*[®] I/O modules" of the following manuals:

- Profibus-DP
German: „*piconet*[®] for PROFIBUS-DP“, D300775
English: „*piconet*[®] for PROFIBUS-DP“, D300776
- DeviceNet
Not yet published
- CANopen
Not yet published

Diagnosis

Diagnostics via LEDs

Please read the description of the diagnostic LEDs in the event of local errors of the coupling and extension modules in Chapter 5 of this manual: Fieldbus-specific diagnostic indications via LEDs are described in the chapter "Error treatment and diagnostics" of the above mentioned manuals.

Diagnostics via software

Detailed information on fieldbus-dependent diagnostics of the modules is contained in the chapter "Error treatment and diagnostics" of the above mentioned manuals.

**Sxxx-0008D-x002/ -x003, 8-port digital output,
24 VDC, $I_{\max} = 2 \text{ A}$**

TURCK

Industrial
Automation

Sxxx-0008D-x002/ -x003, 8-port digital output, 24 VDC, $I_{\max} = 2 \text{ A}$

The digital output modules transfer the binary control signals of the automation device to the actuators at the process level. The 8 outputs process load currents of up to 2 A each, yet the maximum total current is limited to $I_{\Sigma} = 4 \text{ A}$. Thus these modules are particularly suited for applications in which all outputs are not active at the same time or not all actuators require signal currents of 2 A.

The signal status is indicated via LEDs.

The outputs are short-circuit and reverse-polarity protected.

Figure 28:
SDPB-0008D-x00x
SNNE-0008D-000x

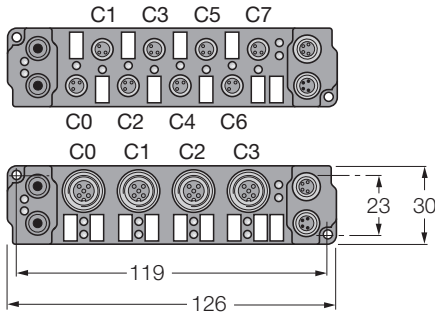
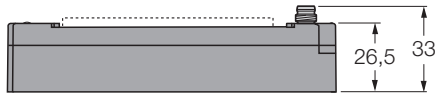
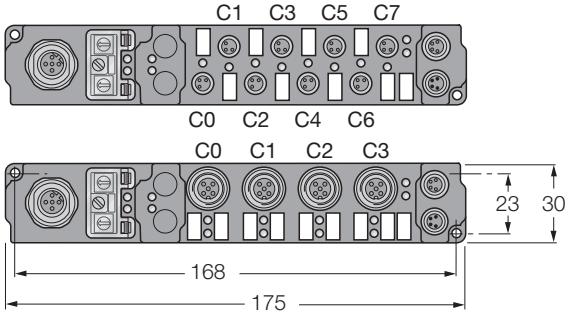
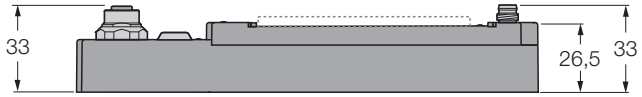

Technical data

Table 25:
 Technical data

Designation	Sxxx-0008D-x002/ -x003
Voltage supply	
Operating voltage U_B	24 VDC (- 15 %/+ 20 %)
Load voltage U_L	24 VDC (- 15 %/+ 20 %)
Number of outputs	8, according to EN 61131-2
Load type	ohmic, inductive, lamp load
Output voltage	24 VDC (- 15 %/+ 20 %)
Output current per channel	max. 2.0 A per channel, each channel is individually short-circuit protected, Total current 4 A max.
Short-circuit current	typically 4 A
Current consumption Load voltage	30 mA. typ./per channel
Switching frequency	500 Hz
Simultaneity factor	0,25
Bits in the process image	8 bits output data
Potential isolation	- Channels/Operating voltage: no - Between the channels: no - Operating voltage/fieldbus: yes

Wiring diagrams

Figure 29:
 Connection to M8

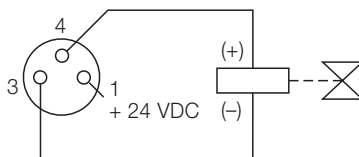
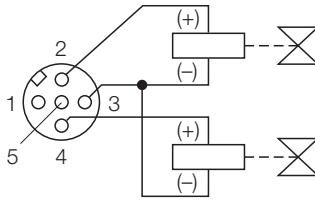

Figure 30:
Connection to the
M12



Parameters

Detailed information on fieldbus-dependent parameterization of the modules is contained in the chapter "Parameters of the *piconet*[®] I/O modules" of the following manuals:

- Profibus-DP
German: „*piconet*[®] for PROFIBUS-DP“, D300775
English: „*piconet*[®] for PROFIBUS-DP“, D300776
- DeviceNet
Not yet published
- CANopen
Not yet published

Diagnosis

Diagnostics via LEDs

Please read the description of the diagnostic LEDs in the event of local errors of the coupling and extension modules in Chapter 5 of this manual: Fieldbus-specific diagnostic indications via LEDs are described in the chapter "Error treatment and diagnostics" of the above mentioned manuals.

Diagnostics via software

Detailed information on fieldbus-dependent diagnostics of the modules is contained in the chapter "Error treatment and diagnostics" of the above mentioned manuals.

Sxxx-0008D-x004/ -x005, 8-port digital output, 24 VDC, $I_{max} = 2 A$

The digital output modules transfer the binary control signals of the automation device to the actuators at the process level. The 8 outputs process load currents of up to 2 A each, yet the maximum total current is limited to $I_{\Sigma} = 12 A$.

The signal status is indicated via LEDs.

The outputs are short-circuit and reverse-polarity protected.

Figure 31:
 SDPB-0008D-x00x
 SNNE-0008D-000x

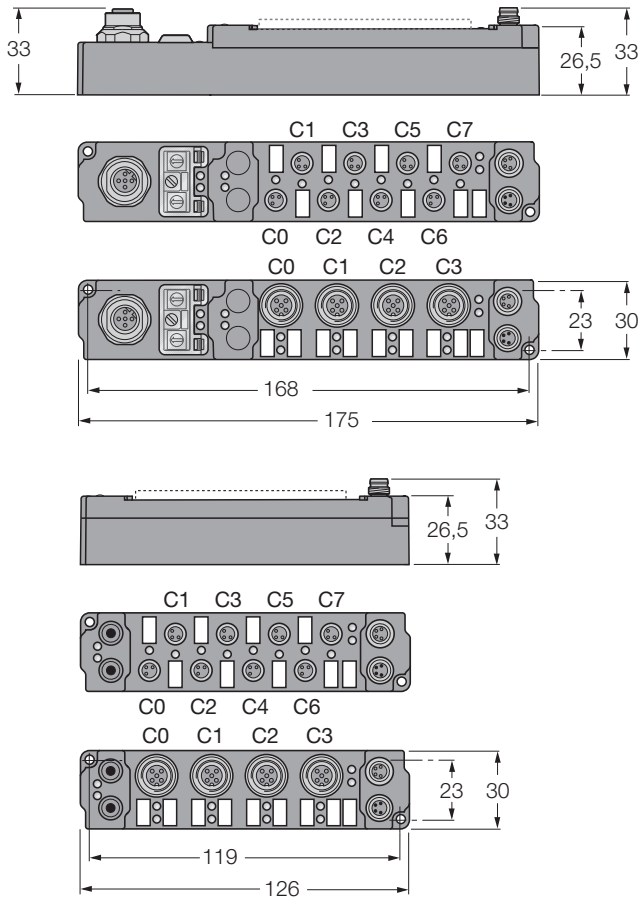

Technical data

Table 26:
Technical data

Designation	Sxxx-0008D-x004/ -x005
Voltage supply	
Operating voltage U_B	24 VDC (- 15 %/+ 20 %)
Load voltage U_L	24 VDC (- 15 %/+ 20 %)
Number of outputs	8, according to EN 61131-2
Load type	ohmic, inductive, lamp load
Output voltage	24 VDC (- 15 %/+ 20 %)
Output current per channel	max. 2.0 A per channel, each channel is individually short-circuit protected, total current 12 A – Channels 0...3 Σ 4 A – Channels 4...5 Σ 4 A – Channels 6...7 Σ 4 A
Short-circuit current	typically 4 A
Current consumption Load voltage	50 mA. typ./per channel
Switching frequency	500 Hz
Simultaneity factor	0,75
Connection Voltage supply	Power supply via: 2 x 4-pole male M8 connectors (see also page 4-6)
Bits in the process image	8 bits output data
Potential isolation	– Channels/Operating voltage: no – Between the channels: no – Operating voltage/fieldbus: yes

Wiring diagrams

Figure 32:
Connection to M8

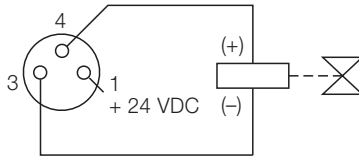
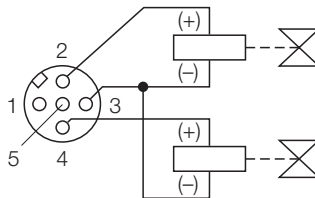

Figure 33:
Connection to the
M12



Parameters

Detailed information on fieldbus-dependent parameterization of the modules is contained in the chapter "Parameters of the *piconet*[®] I/O modules" of the following manuals:

- Profibus-DP
German: „*piconet*[®] for PROFIBUS-DP“, D300775
English: „*piconet*[®] for PROFIBUS-DP“, D300776
- DeviceNet
Not yet published
- CANopen
Not yet published

Diagnosis

Diagnostics via LEDs

Please read the description of the diagnostic LEDs in the event of local errors of the coupling and extension modules in Chapter 5 of this manual: Fieldbus-specific diagnostic indications via LEDs are described in the chapter "Error treatment and diagnostics" of the above mentioned manuals.

Diagnostics via software

Detailed information on fieldbus-dependent diagnostics of the modules is contained in the chapter "Error treatment and diagnostics" of the above mentioned manuals.

Potential groups

With this module the load voltage is fed via three circuits. U_{L1} for channels 0-3 (total current 4 A), U_{L2} for channels 4-5 (total current 4 A) and U_{L3} for channels 6-7 (total current 4 A).

The total current may not be exceeded. That means that merely 2 channels of channels 0...3 with a load of 2 A each may be switched on.

Figure 34:
Potential groups

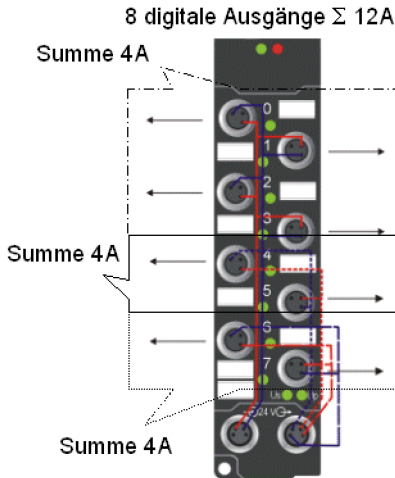

SNNE-0016D-0001, 16 digital outputs 24 VDC, total current max. 4 A

The IE2808 digital output module connects the binary control signals from the automation unit on to the actuators at the process level.

The 16 outputs handle load currents of up to 0.5 A each, although the total current is limited to 4 A.

This makes these modules particularly suitable for applications in which not all of the outputs are active at the same time, or in which not all of the actuators draw 0.5 A current.

An output short-circuit is recognized and passed on to the controller.

The signal state is indicated by means of light emitting diodes.

The signal connection is realized by the 25-pin D-sub socket.

The outputs are short-circuit safe and protected against inverse connection.

Via registers R32 and R33 default values can be activated, which means, these values will be written in case of a communication loss.

In R33, the value On or OFF is set for each output, in R32 this behavior is activated or deactivated.

Figure 35:
SNNE-0016D-0001

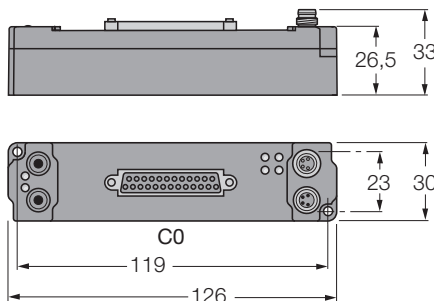

Technical data

Table 27:
Technical data

Designation	SNNE-0016D-0001
Voltage supply	
Operating voltage U_B	24 VDC (- 15 %/+ 20 %)
Load voltage U_L	24 VDC (- 15 %/+ 20 %)
Number of outputs	16
Load type	ohmic, inductive, lamp load
Output voltage	24 VDC (- 15 %/+ 20 %)
Output current per channel	0.5 A (Σ max. 4 A)
Short circuit current	max 1,5 A
Load voltage current consumption	typical 5 mA per channel
Connection Power supply	Feed: 1 x M8 male socket, 4-pole downstream connection: 1 x M8 female socket, 4-pole
Bits in process image	16 bit output, 16 bit input (diagnostic), optional: control/status byte
Electrical isolation	– channels / control voltage: no – between the channels: no – control voltage / fieldbus: yes, via IP-Link

Wiring diagram

Figure 36:
Connection via
25-pole SUB-D
female connector

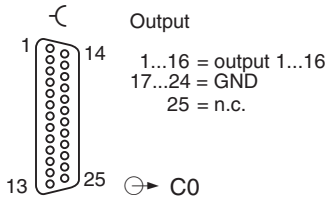

Meaning of the channel LEDs

Table 28:
Channel-LED
displays

LED	Status	Meaning
ERR 1-8	Green	at least one output of the group 1-8 is switched
	Red	at least one output of the group 1-8 has a short-circuit
ERR 9-16	Green	at least one output of the group 9-16 is switched
	Red	at least one output of the group 9-16 has a short-circuit

Parameters

The module has no parameter data available.

Diagnosis

Diagnostics via LEDs

Please read the description of the diagnostic LEDs in the event of local errors of the coupling and extension modules in Chapter 5 of this manual: Fieldbus-specific diagnostic indications via LEDs are described in the chapter "Error treatment and diagnostics" of the above mentioned manuals.

Diagnostics via software

Detailed information on fieldbus-dependent diagnostics of the modules is contained in the chapter "Error treatment and diagnostics" of the above mentioned manuals.

Data mapping



Note

Data mapping of the *piconet*[®] modules depends on the type of fieldbus.

For this, please refer to the mapping descriptions in chapter "Data mapping of the *piconet*[®] modules" of the respective bus-specific manuals.

Control and status byte

Process data operation

■ Control byte

The control byte is only visible, if the module is operated in the complex mode. It is contained in the output image and can be read or written.

Bit	7	6	5	4	3	2	1	0
Name	RegAccess	ResetErr	Set Default Status					

Table 30:
Control byte
description

Name	Description
RegAccess	– 0 = Register communication disabled (Process data operation)
ResetErr	– Sets back errors, displayed at status byte
Set Default-Status	– Sets outputs to default status defined by register R33

■ Status byte

The status byte is only visible, if the module is operated in the complex mode. It is contained in the input image and can only be read.

*Table 31:
Status byte*

Bit	7	6	5	4	3	2	1	0
Name	Reg Access	Error	Under-Voltage	Ovr Current Grp2	Ovr Current Grp1	-	Default Status	-

*Table 32:
Description of the status byte*

Name	Description
RegAccess	0 = Acknowledgement of process data operation
Error	General error bit
Under-Voltage	0 = Load voltage UL = 18 V 1 = Load voltage UL < 18 V, UL-LED shines red, but the outputs stay switched
OvrCurrent Grp2	1 = Short circuit detected at an output of group 2. The concerned output is displayed by the input byte Diag2. After repair this error display has to be set back by bit CB.6 of control byte.
OvrCurrent Grp1	1 = Short circuit detected at an output of group 1. The concerned output is displayed by the input byte Diag1. After repair this error display has to be set back by bit CB.6 of control byte.
Default-Status	1 = Outputs have been set to default status, defined by R33

Register communication

During register communication measuring values cannot be transferred.

■ Control byte

The control byte is only visible, if the module is operated in the complex mode. It is contained in the output image and can be read or written.

Table 33:

Control byte in register communication

Bit	7	6	5	4	3	2	1	0
Name	RegAccess	R/W	Register number					

Table 34:

Control byte description

Name	Description
RegAccess	1 = Register communication enabled
R/W	0 = Read 1 = Write
Register number	Number of the register that is to be read or written.

■ Status byte

The status byte is only visible, if the module is operated in the complex mode. It is contained in the input image and can only be read.

Table 35:

Status byte

Bit	7	6	5	4	3	2	1	0
Name	RegAccess	R/W	Register number					

Table 36:

Control byte description

Name	Description
RegAccess	1 = Acknowledgement for register access
R/W	0 = Read
Register number	Number of the register that is to be read.

Register overview

Table 37:
Register overview
SNNE-0016D-001

Register	Designation	Default value (hex)	Read/Write	Memory
R 0 to R 5	reserved	0000	R	RAM
R 6	diagnostic-Register - not used	0000	R	RAM
R 7	command register - not used	0000	R	RAM
R 8	module type	AF8	R	ROM
R 9	firmware version number	3142	R	ROM
R 10	multiplex shift register	0118	R	ROM
R 11	signal channels	0118	R	ROM
R 12	minimum data length	9898	R	ROM
R 13	data structure	0001	R	ROM
R 14 to R 30	reserved	0001	R	ROM
R 31	code word register	variable	R/W	RAM
R 32	enable default status register	FFFF	R/W	SEEROM
R 33	default status register	0000	R/W	SEEROM

Watchdog Feature (R32-R33)

The behavior of the outputs in case of a communication error can be defined via the Enable Default Status register R32 and the Default Status register R33.

In order to write to the register, it is first required to reset the write protection in the code word register

Registers 32 and 33 define the behavior of every single channel.

Register R32 activates or deactivates the Watchdog Feature.

Register R33 defines the state of the output in case of an error (if Watchdog has been activated).



Attention

When using the watchdog feature, please observe, that during the start-up of an installation no communication is established. The output will thus be set to the default value.

The modules are delivered with an active watchdog feature. The output status is set to "0". All outputs are switched off if an error occurs.

Table 38:
Watchdog
Feature

Reg.	Description	Output	Description	Default
32	Watchdog active	00-15	1 = activated; 0 = deactivated	0xFFFF
33	output state	00-15	1 = ON; 0 = OFF	0x0000

Example:

Register 32 = 1111 1111 1111 1111

Register 33 = 0000 0000 0000 1000

Process data = all outputs ON

In case of a communication error, all outputs are now set to OFF, except for output 3.

Output 3 is set to ON.

SNNE-0016D-0002, 16 digital outputs 24 VDC, total current max. 4 A

Technical data



Note

The module SNNE-0016D-0002 differs from the module SNNE-0016D-0001 (page 8-15) only in the one feature described in the following. All other features of the modules are identical.

The module's error behavior

The module provides an "auto-reset"-function for the error case. Output errors are only shown (at the LED as well as in the status byte) as long as the error occurs at the outputs.



Note

A manual reset of the error messages via bit 6 of the control byte (see page 8-19) is thus not necessary using the module SNNE-0016D-0002!

When the module is delivered, the "auto-reset"-function is activated (R 34, Bit 1 = „1“).

In order to deactivate this function, please set bit 1 in register 34 back to "0". The module's error behavior is now similar to the one of the SNNE-0016D-0001 (page 8-19).

9 Digital combined modules

Type overview.....	2
Sxxx-0404D-x003/-x004/-x001/-x002, 4-port digital input; 4-port digital output.....	3
Technical data	5
Wiring diagrams	6
Parameters	8
Diagnosis	8
– Diagnostics via LEDs	8
– Diagnostics via software	8
Sxxx-0404D-x007/-x008/-x005/-x006, 4-port digital input; 4-port digital output.....	9
Technical data	11
Wiring diagrams	12
Parameters	14
Diagnosis	14
– Diagnostics via LEDs	14
– Diagnostics via software	14
Sxxx-0008D-x001, 8-port digital combined module.....	15
Technical data	17
Wiring diagrams	18
Parameters	19
Diagnosis	19
– Diagnostics via LEDs	19
– Diagnostics via software	19
SNNE-0808D-0003, 8-port digital combined module with IP20 terminals	20
Technical Data.....	21
Wiring diagrams	23
Parameters	24
Diagnosis	24
– Diagnostics via LEDs	24
– Diagnostics via software	24

Type overview

The device type Sxxx-0800D-xxxx is designed for connection of 4 binary switches or sensors as well as 4 binary actuators. The devices come as stand-alone or extension modules and differ in their connection technology, the input filter speed and the various admissible output current ratings.

<i>Table 39: Type overview digital Combined modules</i>	Sxxx-0404D-x00x	Description	Connection technology
	Sxxx-0404D- x003 , Page 9-3	– 4 digital inputs, 24 V DC, filter 3.0 ms	M8
	Sxxx-0404D- x004 , Page 9-3	– 4 digital outputs 24 V DC, $I_{\max} = 0.5 \text{ A}$	M12
	Sxxx-0404D- x001 , Page 9-3	– 4 digital inputs, 24 V DC, filter 0,2 ms	M8
	Sxxx-0404D- x002 , Page 9-3	– 4 digital outputs 24 V DC, $I_{\max} = 0.5 \text{ A}$	M12
	Sxxx-0404D- x007 , Page 9-9	– 4 digital inputs, 24 V DC, filter 3.0 ms	M8
	Sxxx-0404D- x008 , Page 9-9	– 4 digital outputs, 24 V DC, $I_{\max} = 2 \text{ A}$ ($I_{\Sigma} = 4 \text{ A}$)	M12
	Sxxx-0404D- x005 , Page 9-9	– 4 digital inputs, 24 V DC, filter 0,2 ms	M8
	Sxxx-0404D- x006 , Page 9-9	– 4 digital outputs, 24 V DC, $I_{\max} = 2 \text{ A}$ ($I_{\Sigma} = 4 \text{ A}$)	M12
	Sxxx-0808D- x001 , Page 9-15	– 8 digital inputs, 24 V DC, filter 3.0 ms – 8 digital outputs 24 V DC, $I_{\max} = 2 \text{ A}$	M8
	SNNE-0808D- 0003 , Page 9-15	– 8 digital inputs, 24 V DC, filter 3.0 ms – 8 digital outputs 24 V DC, $I_{\max} = 0,5 \text{ A}$	IP20 terminals

Sxxx-0404D-x003/-x004/-x001/-x002, 4-port digital input; 4-port digital output

TURCK

Industrial
Automation

Sxxx-0404D-x003/-x004/-x001/-x002, 4-port digital input; 4-port digital output

These digital I/O modules combine 4 digital inputs with an input filter of 3.0 ms or 0.2 ms and 4 digital 24 V DC outputs in a single device.

The outputs are suited for load currents of 0.5 A; they are short-circuit-proof and reverse-polarity protected.

The signal status can be indicated separately for each channel via LEDs.

The inputs are located on the upper half of the modules. With M8 connection technology modules, these are the upper four connectors (C0 to C3), and with the M12 technology modules the two upper connectors (C0, C1) with two inputs on one connector.

Figure 37:
SDPB-0404D-x00x
SNNE-0404D-000x

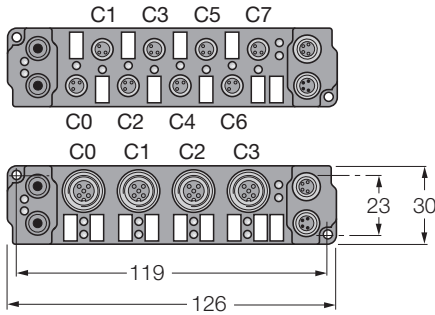
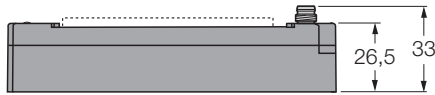
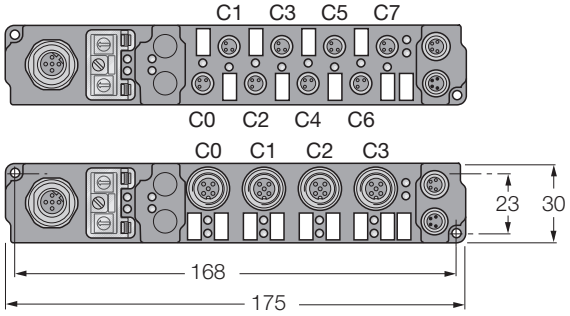
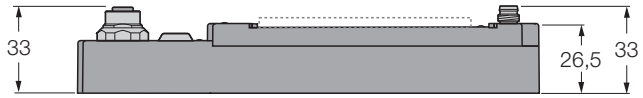

Technical data

Table 40:
Technical data

Designation	Sxxx-0404D-x003, -x004, -x001, -x002
Voltage supply	
Operating voltage U_B	24 VDC (- 15 %/+ 20 %)
Load voltage U_L	24 VDC (- 15 %/+ 20 %)
Inputs	
Number of inputs	4, according to EN 61131-2
Input voltage	24 VDC (-15%/+ 20%)
Supply current	500 mA, short-circuit protected
Input filter	0.2 ms or 3.0 ms
Max. input current	< 7 mA
Switching point 0/1	-3... 5 V / 11...30 V, 6 mA input current (EN 61131-2, type 2)
Sensor supply	from operating voltage U_B , max. 0.5 A per module, common short-circuit protection
Outputs	
Number of outputs	4, according to EN 61131-2
Output voltage	24 VDC (-15%/+ 20%)
Output current per channel	max. 0.5 A per channel, individually short-circuit protected
Load type	ohmic, inductive, lamp load
Short-circuit current	typically 1.5 A (cyclic)
Switching frequency	500 Hz
Simultaneity factor	1

Current consumption	20 mA. typ.
Load voltage	
Bits in the process image	4 input or 4 output bits
Potential isolation	<ul style="list-style-type: none"> - Channels/Operating voltage: no - Between the channels: no - Operating voltage/fieldbus: yes

Wiring diagrams

Figure 38:
Connection to M8

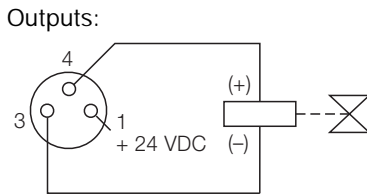
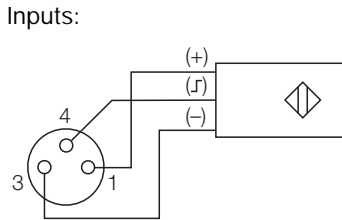
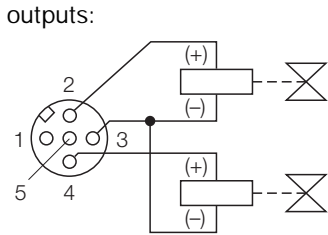
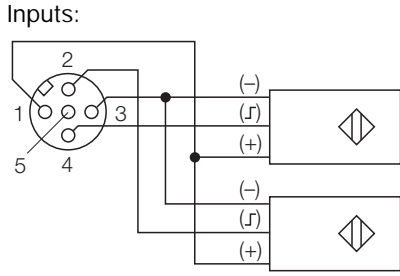

Figure 39:
Connection to the
M12



Parameters

Detailed information on fieldbus-dependent parameterisation of the modules is contained in the chapter "Parameters of the *piconet*[®] I/O modules" of the following manuals:

- Profibus-DP
German: „*piconet*[®] for PROFIBUS-DP“, D300775
English: „*piconet*[®] for PROFIBUS-DP“, D300776
- DeviceNet
Not yet published
- CANopen
Not yet published

Diagnosis

Diagnostics via LEDs

Please read the description of the diagnostic LEDs in the event of local errors of the coupling and extension modules in Chapter 5 of this manual: Fieldbus-specific diagnostic indications via LEDs are described in the chapter "Error treatment and diagnostics" of the above mentioned manuals.

Diagnostics via software

Detailed information on fieldbus-dependent diagnostics of the modules is contained in the chapter "Error treatment and diagnostics" of the above mentioned manuals.

Sxxx-0404D-x007/-x008/-x005/-x006, 4-port digital input; 4-port digital output



**Sxxx-0404D-x007/-x008/-x005/-x006,
4-port digital input; 4-port digital output**

These digital I/O modules combine 4 digital inputs with an input filter of 3.0 ms or 0.2 ms and 4 digital 24 V DC outputs in a single device. The 8 outputs process load currents of up to 2 A each; the maximum total current is limited to $I_{\Sigma} = 4$ A.

The outputs are short-circuit and reverse-polarity protected.

The signal status can be indicated separately for each channel via LEDs.

The inputs are located on the upper half of the modules. With M8 connection technology modules, these are the upper four connectors (C0 to C3), and with the M12 technology modules the two upper connectors (C0, C1) with two inputs on one connector.

Figure 40:
SDPB-0404D-x00x
SNNE-0404D-000x

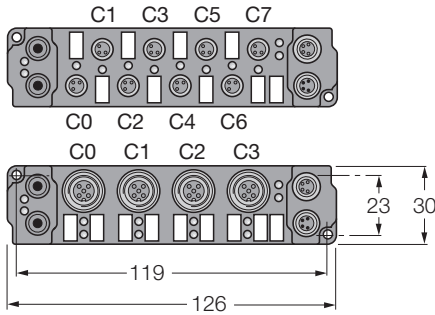
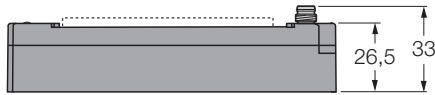
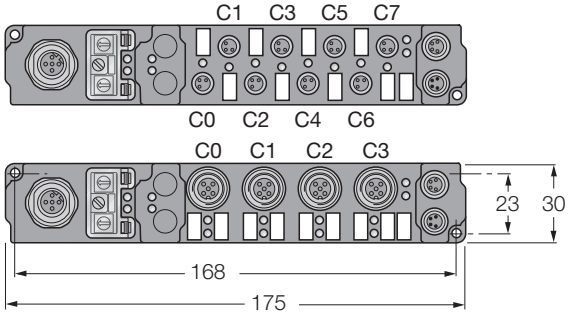
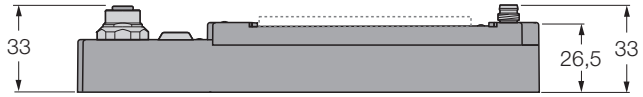

Technical data

Table 41:
Technical data

Designation	Sxxx-0404D-x007/ -x008/ -x005/ -x006
Voltage supply	
Operating voltage U_B	24 VDC (- 15 %/+ 20 %)
Load voltage U_L	24 VDC (- 15 %/+ 20 %)
Inputs	
Number of inputs	4, according to EN 61131-2
Input voltage	24 VDC (-15%/+ 20%)
Supply current	500 mA, short-circuit protected
Input filter	3.0 ms and 0.2 ms
Max. input current	< 7 mA
Switching point 0/1	-3... 5 V / 11...30 V, 6 mA Input current (EN 61131-2, type 2)
Sensor supply	from operating voltage U_B , max. 0.5 A per module, common short-circuit protection
Outputs	
Number of outputs	4, according to EN 61131-2
Output voltage	24 VDC (-15%/+ 20%)
Output current per channel	max. 2 A per channel; $I_{\Sigma} = 4$ A; individually short-circuit protected
Load type	ohmic, inductive, lamp load
Short-circuit current	typically 1.5 A (cyclic)
Switching frequency	500 Hz
Simultaneity factor	1

Current consumption	20 mA. typ.
Load voltage	
Bits in the process image	4 input or 4 output bits
Potential isolation	<ul style="list-style-type: none"> - Channels/Operating voltage: no - Between the channels: no - Operating voltage/fieldbus: yes

Wiring diagrams

Figure 41:
Connection to M8

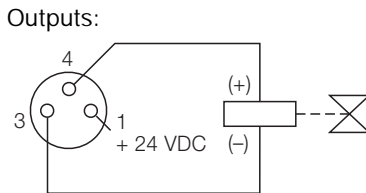
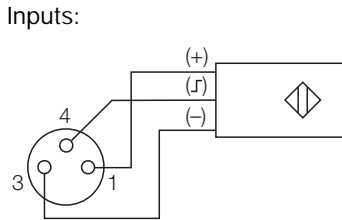
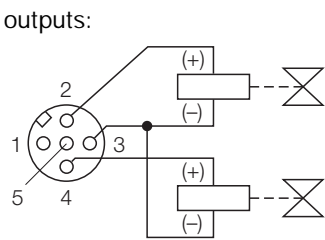
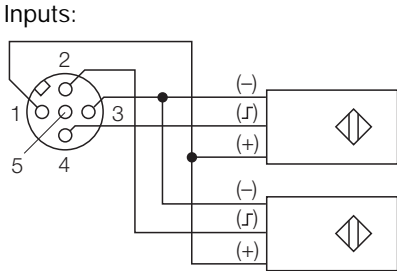

Figure 42:
Connection to the
M12



Parameters

Detailed information on fieldbus-dependent parameterisation of the modules is contained in the chapter "Parameters of the *piconet*[®] I/O modules" of the following manuals:

- Profibus-DP
German: „*piconet*[®] for PROFIBUS-DP“, D300775
English: „*piconet*[®] for PROFIBUS-DP“, D300776
- DeviceNet
Not yet published
- CANopen
Not yet published

Diagnosis

Diagnostics via LEDs

Please read the description of the diagnostic LEDs in the event of local errors of the coupling and extension modules in Chapter 5 of this manual: Fieldbus-specific diagnostic indications via LEDs are described in the chapter "Error treatment and diagnostics" of the above mentioned manuals.

Diagnostics via software

Detailed information on fieldbus-dependent diagnostics of the modules is contained in the chapter "Error treatment and diagnostics" of the above mentioned manuals.

Sxxx-0008D-x001, 8-port digital combined module

The device type Sxxx-0800D is designed for connection of 8 binary switches or sensors and 8 binary actuators.

These digital I/O modules provide 8 digital inputs with an input filter of 3.0 ms or alternatively 8 digital 24 V DC outputs.

A maximum current of 0.5 A per actuator is permitted. The outputs are short-circuit and reverse-polarity protected.

An LED is assigned to each input and output for switching status indications.

Figure 43:
SDPB-0808D-x001
SNNE-0808D-0001

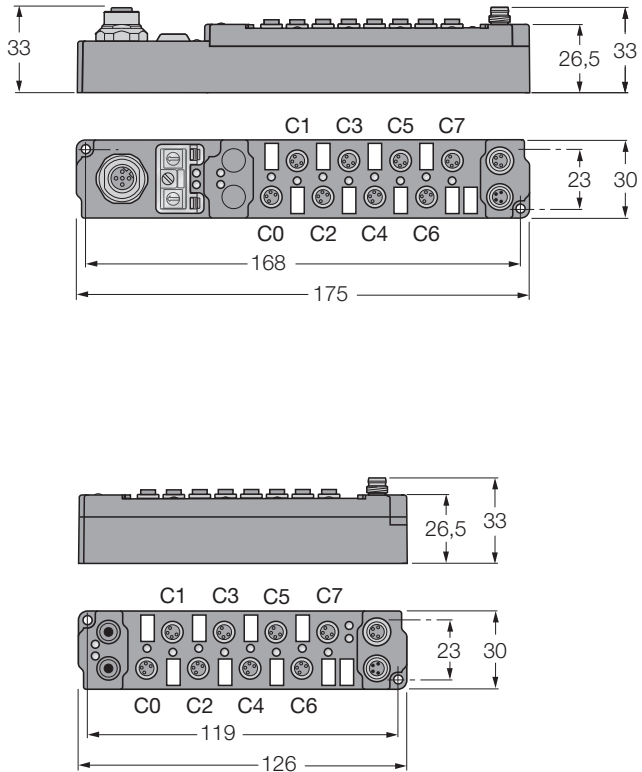

Technical data

Table 42:
Technical data

Designation	Sxxx-0808D-x001
Voltage supply	
Operating voltage U_B	24 VDC (- 15 %/+ 20 %)
Load voltage U_L	24 VDC (- 15 %/+ 20 %)
Inputs	
Number of inputs	8, according to EN 61131-2
Input voltage	24 VDC (-15%/+ 20%)
Supply current	500 mA, short-circuit protected
Input filter	3.0 ms
Max. input current	< 7 mA
Switching point 0/1	-3... 5 V / 11...30 V, 6 mA input current (EN 61131-2, type 2)
Sensor supply	from operating voltage U_B , max. 0.5 A per module, common short-circuit protection
Outputs	
Number of outputs	8, according to EN 61131-2
Output voltage	24 VDC (-15%/+ 20%)
Output current per channel	0.5 A max. individually short-circuit protected
Load type	ohmic, inductive, lamp load
Short-circuit current	typically 1.5 A (cyclic)
Switching frequency	500 Hz
Simultaneity factor	1

Current consumption	20 mA. typ.
Load voltage	
Bits in the process image	8 input or 8 output bits
Potential isolation	<ul style="list-style-type: none"> - Channels/Operating voltage: no - Between the channels: no - Operating voltage/fieldbus: yes

Wiring diagrams

Figure 44:
Connection to M8

Inputs:

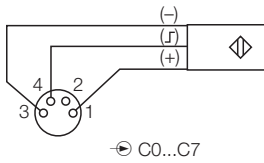

Outputs:

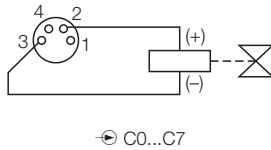

Parameters

Detailed information on fieldbus-dependent parameterisation of the modules is contained in the chapter "Parameters of the *piconet*[®] I/O modules" of the following manuals:

- Profibus-DP
German: „*piconet*[®] for PROFIBUS-DP“, D300775
English: „*piconet*[®] for PROFIBUS-DP“, D300776
- DeviceNet
Not yet published
- CANopen
Not yet published

Diagnosis

Diagnostics via LEDs

Please read the description of the diagnostic LEDs in the event of local errors of the coupling and extension modules in Chapter 5 of this manual: Fieldbus-specific diagnostic indications via LEDs are described in the chapter "Error treatment and diagnostics" of the above mentioned manuals.

Diagnostics via software

Detailed information on fieldbus-dependent diagnostics of the modules is contained in the chapter "Error treatment and diagnostics" of the above mentioned manuals.

SNNE-0808D-0003, 8-port digital combined module with IP20 terminals

The digital combi module SNNE-0808D-0003 has 16 channels with 8 inputs and 8 outputs.

The device can therefore be flexibly adapted to the requirements of the application.

The outputs handle load currents of up to 0.5 A. They are short-circuit-proof and protected against inverse polarity.

IP20 terminal tension spring connectors are used for the signal connection. These connectors are optionally available with 1 or 3 rows.



Note

The IP20 terminal tension spring connectors (1-row: SNNE-BL I/O 3,5-10/LED-SET, Ident.-No. 6824475 and 3-rows SNNE-BL I/O 3,5-30/LED-SET, Ident.-Nr. 6824474) are not supplied with the module but can be ordered separately.

Figure 45:
SNNE-0808D-0003

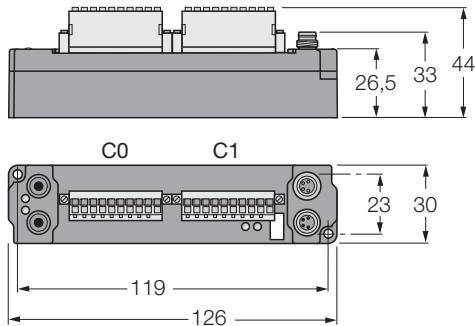

Technical Data

Table 43:
Technical data

Designation	SNNE-0808D-0003
Voltage supply	
Operating voltage U_B	24 VDC (- 15 %/+ 20 %)
Load voltage U_L	24 VDC (- 15 %/+ 20 %)
Inputs	
Number of inputs	8, according to EN 61131-2
Input voltage	24 VDC (-15 %/+ 20 %)
Supply current	500 mA, short-circuit protected
Input filter	3.0 ms
Max. input current	< 7 mA
Input type	3-wire pnp sensors
Switching point 0/1	-3... 5 V / 11...30 V, 6 mA input current (EN 61131-2, type 2)
Sensor supply	from operating voltage U_B , max. 0.5 A per module, common short-circuit protection
Connection technology	terminals with spring connectors
Outputs	
Number of outputs	8, according to EN 61131-2
Output voltage	24 VDC (-15 %/+ 20 %)
Output current per channel	0.5 A max. individually short-circuit protected
Load type	ohmic, inductive, lamp load
Short-circuit current	typically 1.5 A (cyclic)
Switching frequency	500 Hz

Simultaneity factor	1
Current consumption Load voltage	20 mA. typ.
Connection technology	terminals with spring connectors
Bits in the process image	8 input or 8 output bits
Potential isolation	<ul style="list-style-type: none">- Channels/Operating voltage: no- Between the channels: no- Operating voltage/fieldbus: yes

Wiring diagrams

Figure 46:
Connection IP20
terminals

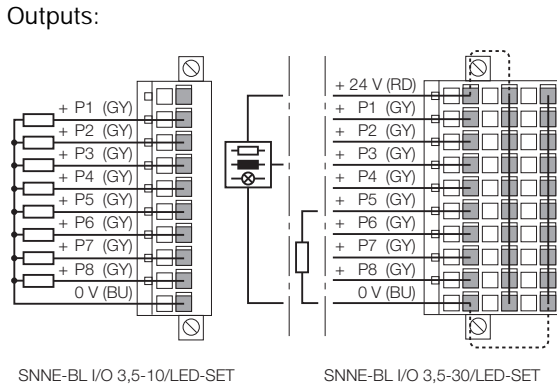
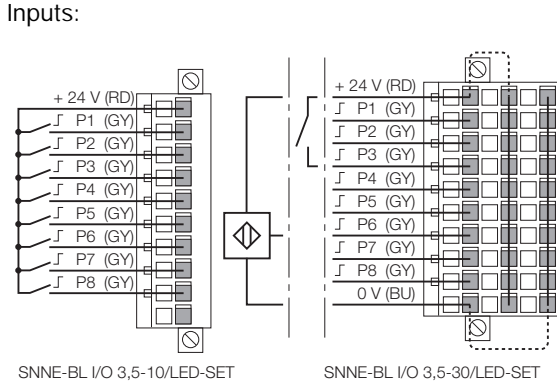

Parameters

Detailed information on fieldbus-dependent parameterisation of the modules is contained in the chapter "Parameters of the *piconet*[®] I/O modules" of the following manuals:

- Profibus-DP
German: „*piconet*[®] for PROFIBUS-DP“, D300775
English: „*piconet*[®] for PROFIBUS-DP“, D300776
- DeviceNet
Not yet published
- CANopen
Not yet published

Diagnosis

Diagnostics via LEDs

Please read the description of the diagnostic LEDs in the event of local errors of the coupling and extension modules in Chapter 5 of this manual: Fieldbus-specific diagnostic indications via LEDs are described in the chapter "Error treatment and diagnostics" of the above mentioned manuals.

Diagnostics via software

Detailed information on fieldbus-dependent diagnostics of the modules is contained in the chapter "Error treatment and diagnostics" of the above mentioned manuals.

10 Analogue input modules

Type overview	3
Sxxx-40A-x005, 4-port analogue input module, -10/ 0 to +10 V	4
Technical data	6
Wiring diagrams	7
Supply voltage.....	8
Functions of the channel LEDs	9
Process data	9
Parameters	10
Diagnosis	10
– Diagnostics via LEDs	10
– Diagnostics via software	10
Data mapping	10
Control and status byte	11
– Process data operation	11
– Register communication	13
Register overview	14
– Feature register (R32)	15
– User offset (R33)	17
– User gain (R34)	18
– Filter register (R37)	19
Sxxx-40A-x007, 4-port analogue input module, 0/(4) to 20 mA	22
Technical data	24
Wiring diagrams	25
Functions of the channel LEDs	26
Process data	26
Parameters	28
Diagnosis	28
– Diagnostics via LEDs	28
– Diagnostics via software	28
Data mapping	28
Control and status byte	29
– Process data operation	29
– Register communication	31
Register overview	32
Feature register (R32)	33
– User offset (R33) and user gain (R34)	35

- Filter register (R37)35

Sxxx-40A-x009,	
4-port analogue input module for Pt100 (RTD)	36
Technical data	38
Wiring diagrams	39
Supply voltage.....	40
Functions of the channel LEDs	41
Process data	41
Parameters	42
Diagnosis	42
– Diagnostics via LEDs	42
– Diagnostics via software	42
Data mapping	42
Control and status byte.....	43
– Process data operation	43
– Register communication	44
Register overview	45
Feature register (R32)	47
– User offset (R33) and user gain (R34)	51
– Filter register (R37)	51
Sxxx-40A-x004,	
4-port analogue input module for thermoelements	52
Technical data	54
Wiring diagrams	55
Supply voltage.....	57
Functions of the channel LEDs	57
Function principle	58
– Process data output format	59
Parameters	60
Diagnosis	60
– Diagnostics via LEDs	60
– Diagnostics via software	60
Data mapping	60
Control and status byte.....	61
– Process data operation	61
– Register communication	62
Register overview	64
– Feature register (R32)	66
– User scaling	68
– User offset (R33) and user gain (R34)	70
– Filter register (R37)	70

Type overview

<i>Table 44: Type overview analogue input modules</i>	Sxxx-40A-x00x	Description	Connection technology
	Sxxx-40A- x005 , Page 10-5	– 4 analogue differential voltage inputs +/- 10 V	M12
	Sxxx-40A- x007 , Page 10-23	– 4 analogue differential inputs 0/(4)...20 mA	M12
	Sxxx-40A- x009 , Page 10-37	– 4 analogue inputs for Pt100 (RTD)	M12
	Sxxx-40A- x004 , Page 10-53	– 4 analogue inputs for thermoelements	M12

**Sxxx-40A-x005, 4-port analogue input module,
-10/ 0 to +10 V**

The analogue input modules Sxxx-40A-x005 process signals in a range of -10V to +10V. The voltage is digitised with a resolution of 16 bits, galvanically isolated and transferred to the higher level automation device.

The 4 input channels are differential inputs and have a common internal ground potential. The provided load voltage U_L (freely selectable up to 30 VDC) is used to power the connected sensors. Thus it is possible, for instance, to power a measuring potentiometer with 10 VDC via an external voltage source.

This module is equipped with various features. The default settings have been selected in such a way that device configuration is usually not necessary.

The input filters and thus the associated conversion times are adjustable within wide ranges. There are multiple data output formats available.

The input scaling may be modified if required; an automatic limit value monitoring function is also provided.

The module is either parameterised via the fieldbus or the additional configuration tool "I/O-ASSISTANT" via the configuration interface. Parameters are stored permanently in the module, even in the event of a power failure.

Figure 47:
SDPB-40A-x005,
SNNE-40A-0005

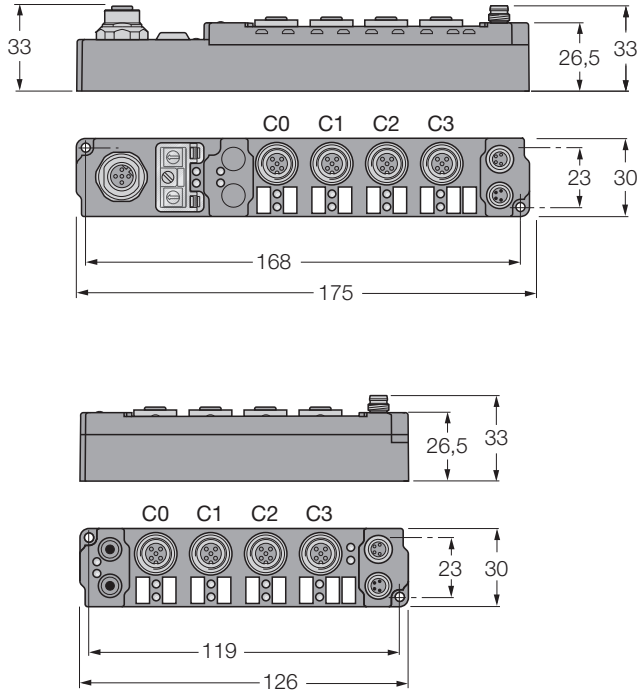

Technical data

Table 45:
Technical data

Designation	Sxxx-40A-x005
Voltage supply	
Operating voltage U_B	24 VDC (- 15 %/+ 20 %)
Load voltage U_L	24 VDC (- 15 %/+ 20 %)
Number of inputs	4
Input range (nominal value)	-10 V/ 0 V to +10 V
Input resistance	> 100 k Ω
Common mode voltage	max. 35 V
Resolution	15 bits + sign
Conversion time	250 ms, configurable up to 5 ms
Relative measuring error	< $\pm 0,3\%$ of final measuring value
Current consumption Load voltage	120 mA typ. (additional current consumption of the module)
Input filter	10 versions incl. average forming, configurable
Sensor supply	from load voltage U_L , freely selectable up to 30 V
Bytes in the process image	depending on mapping – Compact: 2 input data bytes per channel – Complex: 2 input and 2 output data bytes per channel + 1 status and 1 control byte per channel

Potential isolation

- Channels/Operating voltage: 500 V_{eff}
 - Between the channels: no
 - Operating voltage/fieldbus: yes
-

Wiring diagrams

The analogue input signal is measured via a differential input. If the sensor does not provide two lines for differential measurement (e.g. 24 V, GND and signal), then GND and input must be jumpered.



Note

Pin 5 (shield) is capacitively coupled to the conductive base surface of the *piconet*® module.

Figure 48:
Connection to the
M12

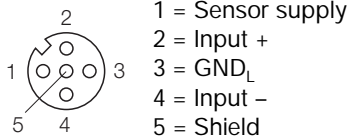

Connection types:

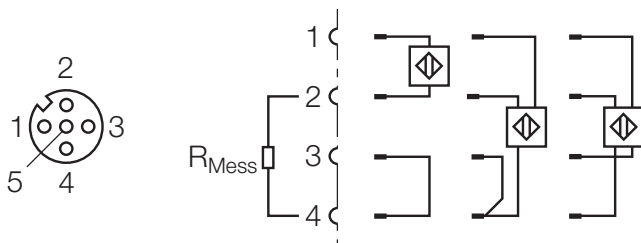

Supply voltage

U_B powers the fieldbus and the sensor electronics. It is galvanically isolated from U_L .

U_L is not needed for module function. An infeed is not needed.



Attention

Should you use U_L for a feed-through arrangement, please note that galvanic isolation is neutralized through feed-through of the load voltage when connecting a module without galvanic isolation between U_B and U_L (i.e. all digital modules).

Functions of the channel LEDs

Table 46:
Channel LED
indications

LED	Status	Meaning
R "Run"	Green	Data are transferred to the D/A converter.
	OFF	Presently, there is no data transfer.
E "Error"	red	Data transmission error Example: – Wire-break – Measuring value out of range – Temperature compensation out of valid range
	OFF	Error-free data transfer

Process data

The analogue input module processes signals from -10 V to 10 V with a resolution of 16 bits. The filter constants and thus the associated conversion times are adjustable within wide ranges.

Table 47:
Presentation of
process data

Process data		Measuring value
hex	Decimal	
8000	-32768	-10 V
C001	-16383	-5 V
0000	0	0
3FFF	16383	5 V
7FFF	32767	10 V

Parameters

Detailed information on fieldbus-dependent parameterisation of the modules is contained in the chapter "Parameters of the *piconet*[®] I/O modules" of the following manuals:

- Profibus-DP
German: „*piconet*[®] for PROFIBUS-DP", D300775
English: „*piconet*[®] for PROFIBUS-DP", D300776
- DeviceNet
Not yet published
- CANopen
Not yet published

Diagnosis

Diagnostics via LEDs

Please read the description of the diagnostic LEDs in the event of local errors of the coupling and extension modules in Chapter 5 of this manual: Fieldbus-specific diagnostic indications via LEDs are described in the chapter "Error treatment and diagnostics" of the above mentioned manuals.

Diagnostics via software

Detailed information on fieldbus-dependent diagnostics of the modules is contained in the chapter "Error treatment and diagnostics" of the above mentioned manuals.

Data mapping



Note

Data mapping of the *piconet*[®] modules depends on the type of fieldbus.

For this, please refer to the mapping descriptions in chapter "Data mapping of the *piconet*[®] modules" of the respective bus-specific manuals.

Control and status byte

Process data operation

■ Control byte

The control byte is only visible, if the module is operated in the complex mode. It is contained in the output image and can be read or written.

Table 48:
Control byte

Bit	7	6	5	4	3	2	1	0
Name	RegAccess							

Table 49:
Control byte
description

Name	Description
RegAccess	- 0 = Register communication disabled (Process data operation)

■ Status byte

The status byte is only visible, if the module is operated in the complex mode. It is contained in the input image and can only be read.

Table 50:
Status byte

Bit	7	6	5	4	3	2	1	0
Name	Reg Access	Error	Limit value 2		Limit value 1	Over- range		Under- range

Table 51:
Description of the
status byte

Name	Description
RegAccess	0 = Acknowledgement of process data operation
Error	General error bit
Limit value 2	- 00 = Limit value not active
limit value 1	- 10 = Process data < Limit value - 01 = Process data > Limit value - 11 = Process data = Limit value
Over-range	- 0 = No over-range - 1 = Over-range → measuring range exceeded (> 10 V/ > 0x7FFF), if "Overflow-Offset inactive" (R32 Bit 4 = 0); → measuring value ≥ 10.5 V, if "Overflow-Offset active" (R32 Bit 4 = 1)
Under range	- 0 = No under-range 1 = Under-range → below measuring range (< -10 V/ > 0x7FFF), if "Overflow-Offset inactive" (R32 Bit 4 = 0); → measuring value ≤ -10.5 V, if "Overflow-Offset active" (R32 Bit 4 = 1)



Note

In order modify the "over" and "under"-range, it is required to adjust the user scaling function.

For example:

You want to set an "over-range" of 10.6 V. For this you have to activate the user scaling function and set the gain in register 34 to 0x00F0. The measuring range now goes up to 10.6 V (max. of 11.8 V possible).

Register communication

During register communication measuring values cannot be transferred.

■ Control byte

The control byte is only visible, if the module is operated in the complex mode. It is contained in the output image and can be read or written.

<i>Table 52: Control byte in register communication</i>	Bit	7	6	5	4	3	2	1	0
	Name	RegAccess	R/W	Register number					

<i>Table 53: Control byte description</i>	Name	Description
	RegAccess	1 = Register communication enabled
	R/W	0 = Read 1 = Write
	Register number	Number of the register that is to be read or written.

■ Status byte

The status byte is only visible, if the module is operated in the complex mode. It is contained in the input image and can only be read.

<i>Table 54: Status byte</i>	Bit	7	6	5	4	3	2	1	0
	Name	RegAccess	R/W	Register number					

<i>Table 55: Control byte description</i>	Name	Description
	RegAccess	1 = Acknowledgement for register access
	R/W	0 = Read
	Register number	Number of the register that is to be read.

Register overview

Table 56:
Register overview
Sxxx-40A-x005

Register	Designation	Default value (hex)	Read/ Write	Memory
R 0	ADC non-linearised value	Variable	R	RAM
R 1 to R7	reserved	0000	R	
R 8	Module type	0C1E	R	ROM
R 9	Software version	XXXX	R	ROM
R 10	Multiplex shift register	0418	R	ROM
R 11	Signal channels	0418	R	ROM
R 12	Minimum data length	0098	R	ROM
R 13	Data structure	0004	R	ROM
R 14	reserved	0000	R	
R 15	Alignment register	Variable	R/W	RAM
R 16	Hardware version number	XXXX	R/W	SEEROM
R 17	Hardware comparison: Offset	Specific	R/W	SEEROM
R 18	Hardware comparison: Gain	Specific	R/W	SEEROM
R 19	Manufacturer scaling: Offset	0000	R/W	SEEROM
R 20	Manufacturer scaling: Gain	0100	R/W	SEEROM
R 21 to R 30	reserved	0000	R/W	
R 31	Codeword register	Variable	R/W	RAM
R 32	Feature register	0010	R/W	SEEROM

Register Designation		Default value (hex)	Read/ Memory Write	
R 33	User offset	0000	R/W	SEEROM
R 34	User gain	0100	R/W	SEEROM
R 35	Limit value 1	0000	R/W	SEEROM
R 36	Limit value 2	0000	R/W	SEEROM
R 37	Filter register	3200	R/W	SEEROM
R 38 to R63	reserved	0000	R/W	

Feature register (R32)

The basic settings of the module can be modified in the feature register. In order to write to the register, it is first required to reset the write protection in the code word register (R31). Write the value [0x1235] to the register 31.

Default: 0x0010



Note

Detailed information on register communication can be taken from chapter 3 "Register communication".

Table 57:
Feature register
Sxxx-40A-x005

	Bit	Value	Description
A Default setting	0	0	User scaling inactive A
		1	User scaling active
	1	0	Manufacturer scaling inactive
		1	Manufacturer scaling active A
	2	0	reserved
	3	0	Signed number representation inactive A (two's-complement representation → -1 = 0xFFFF)
		1	Signed number representation active (-1 = 0x8001)
	4	0	Overflow offset inactive
		1	Overflow offset active A
	5 to 8		reserved
	9	0	Limit value 1 inactive A
		1	Limit value 1 active (R35)
	10	0	Limit value 2 inactive A
		1	Limit value 2 active (R36)
11 to 15		reserved	

Overflow offset

If this bit is set, the actual voltage value is monitored. The status byte indicates a possible over- / or under-range.

If this bit is not set, process data (> 0x7FFF oder > 0xFFFF) are monitored, depending on the manufacturer scaling. In this case, the status byte will also indicate a possible over- / or under-range.

User offset (R33)

Register 33 is used to adjust the user offset. The following table shows the assignment of register value to offset:

Table 58:
User offset

A Default
setting

Value R33 (hex)	Offset in % of the measuring value
8000	- 50%
...	...
C000	- 25%
...	...
...	...
FFFF	$-100/65535\% = - 0,0015269$
0000 A	0%
0001	$+100/65535\% = +0,0015269$
...	...
...	...
3FFF	+ 25%
...	...
7FFF	+ 50%

User gain (R34)

The following amplification (gain) factors apply to calculation of the user gain:

<i>Table 59: User gain</i>	Value R34 (hex)	Gain factor
A <i>Default setting</i>	0800	x 8

	0400	x 4

	0200	x 2

	0100 A	x 1

	0080	x 0,5

	0040	x 0,25

	0020	x 0,125

	0010	x 0.0625

Filter register (R37)

The modules possess two low pass filter stages. The first stage consists of a sinc³ filter. This is always active.

The second stage consists of an FIR 22nd order filter which can be deactivated.

The filter settings always apply to all channels and are set in the first register of channel 1. Default settings: 0x3200.



Note

The settings will only be activated after a power reset.

Table 60:
Filter register
Sxxx-40A-x005

Bit	15	14	13	12	11	10	9	8	7	6	5	4	3	2	1	0
Name	SF11	SF10	SF9	SF8	SF7	SF6	SF5	SF4	SF3	SF2	SF1	SF0	0	0	SKIP	FAST

Table 61:
Filter register

Name	Description
FAST	<p>0 = Disabled 1 = Enabled</p> <p>If activated, there is a fast response to input step changes (despite activated 2nd filter stage) and the filter is skipped during the next A/D conversions and the value is averaged.</p>
SKIP	<p>0 = FIR filter active 1 = FIR filter is skipped.</p> <p>With activated SKIP mode, the FAST mode is irrelevant.</p>
Bit 2 and bit 3	These two bits must be identical!
SF0 to SF11	<p>This is the actual filter constant. It determines the 3 dB limit frequency of the sinc³ filter. The value range goes from 150 to 2047. The 3 dB limit frequency, or the 64.5 dB stop frequency F_{stop} are listed in the following table and are calculated as follows:</p> <ul style="list-style-type: none"> - SKIP = 0 <ul style="list-style-type: none"> SF = 11981/ F_{limit} SF = 43008/ F_{stop} - SKIP = 1 <ul style="list-style-type: none"> SF = 80486/ F_{limit}

For example:

You want to set a limit frequency of 75 Hz:

$$\begin{aligned}
 SF &= 11981 / F_{\text{limit}} \\
 &= 11981 / 75 \\
 &= 160_{\text{dec}} \\
 &= 0000_1010_0000 \text{ bin} + \text{Low-Byte} \\
 &= 0000_1010_0000_0000 \text{ bin} \\
 &= \underline{\underline{0x0A00}}
 \end{aligned}$$

Table 62:
Register
settings

	Register 37	F_{stop} [Hz]	F_{limit} [Hz]	Cycle time [ms]
SKIP = 0 FAST = 0	0x0A00	270	75	50
	0x1400	135	38	100
	0x1E00	90	25	150
	0x2800	68	19	200
	0x3200	54	15	250
SKIP = 0 FAST = 1	0x0781			5
	0x0F01			10
	0x1681			15
	0x1E01			20
	0x2581			25
SKIP = 1 FAST = x	0x0782		671	5
	0x0F02		335	10
	0x1682		224	15
	0x1E02		168	20
	0x2582		134	15

**Sxxx-40A-x007,
4-port analogue input module, 0/(4) to 20 mA**

The analogue input modules Sxxx-40A-x007 process signals in a range of 0/(4) to 20 mA. The input current is digitised with a resolution of 16 bits, galvanically isolated and transferred to the higher level automation device.

The 4 input channels are differential inputs and have a common internal ground potential.

This module is equipped with various features. The default settings have been selected in such a way that device configuration is usually not necessary.

The input filters and thus the associated conversion times are adjustable within wide ranges and several data output formats are available.

The input scaling may be modified if required; an automatic limit value monitoring function is also provided.

The module is either parameterised via the fieldbus or the additional configuration tool "I/O-ASSISTANT" via the configuration interface.

Parameters are stored permanently in the module, even in the event of a power failure.

Figure 49:
SDPB-40A-x007,
SNNE-40A-0007

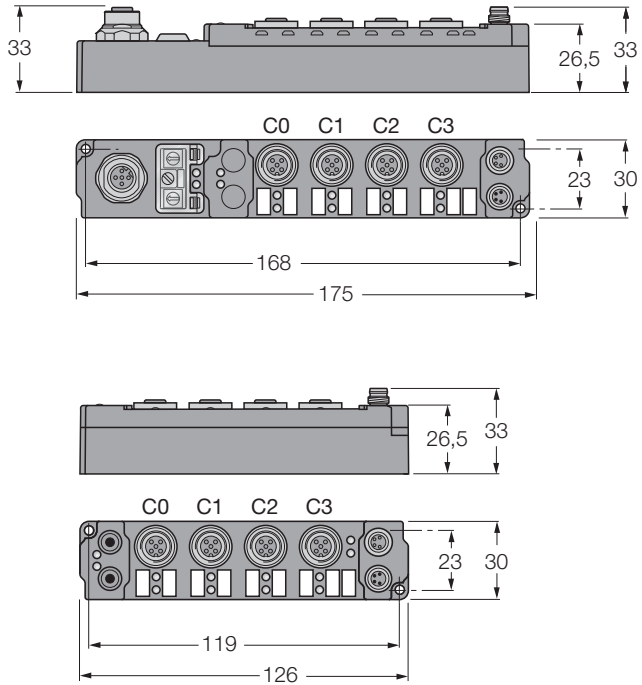

Technical data

Table 63:
Technical data

Designation	Sxxx-40A-x007
Voltage supply	
Operating voltage U_B	24 VDC (- 15 %/+ 20 %)
Load voltage U_L	24 VDC (- 15 %/+ 20 %)
Number of inputs	4
Input range (nominal value)	0(4) to 20 mA
Input resistance	80 Ω measuring resistance
Common mode voltage	max. 35 V
Resolution	16 bits
Conversion time	250 ms, configurable up to 5 ms
Relative measuring error	< \pm 0,3% of final measuring value
Current consumption Load voltage	120 mA typ. (additional current consumption of the module)
Input filter	10 versions incl. average forming, configurable
Sensor supply	from load voltage U_L , freely selectable up to 30 V
Bytes in the process image	depending on mapping – Compact: 2 input data bytes per channel – Complex: 2 input and 2 output data bytes per channel + 1 status and 1 control byte per channel
Potential isolation	– Channels / operating voltage 500 V_{eff} : no – Between the channels: no – Operating voltage/fieldbus: yes

Wiring diagrams

The analogue input signal is measured via a differential input. If the sensor does not provide two lines for differential measurement (e.g. 24 V, GND and signal), then GND and input must be jumpered.



Note

Pin 5 (shield) is capacitively coupled to the conductive base surface of the *piconet*® module.

Figure 50:
Connection to the
M12

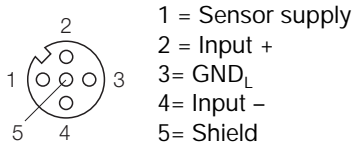

Connection types:

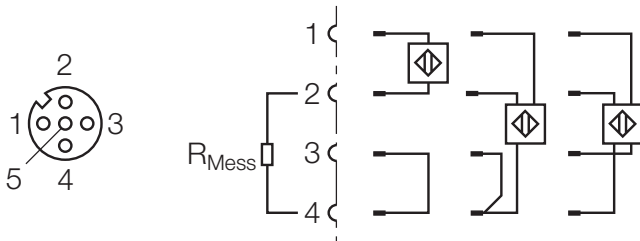

Attention

Should you use U_L for a feed-through arrangement, please observe during connection of a module without galvanic isolation between U_B and U_L (i.e. all digital modules) that galvanic isolation is neutralized through a feed-through of the load voltage.

Functions of the channel LEDs

Table 64:
Channel LED
indications

LED	Status	Meaning
R "Run"	Green	Data are transferred to the D/A converter.
	OFF	Presently, there is no data transfer.
E "Error"	red	Data transmission error Example: – Wire-break – Measuring value out of range
	OFF	Error-free data transfer

Process data

The analogue input module processes signals from 0/4 to 20 mA with a resolution of 16 bits. The filter constants and thus the associated conversion times are adjustable within wide ranges.

Table 65:
Adjustment of the
measuring values
"0 to 20 mA"

Process data		Measuring value
hex	Decimal	
0000	0	0 mA
3FFF	16383	10 mA
7FFF	32767	20 mA



Note

From software version "3" on of the I/O board of the stand-alone modules and software version "0" of the I/O board of the extension modules, the range of 4 to 20 mA can be set in register 32 (bit 5 = 1). This setting in feature register (R32) can be selected separately for each channel.

Table 66:
Adjustment of the
measuring values
"4 to 20 mA"

Process data		Measuring value
hex	Decimal	
0000	0	4 mA
3FFF	16383	12 mA
7FFF	32767	20 mA

Data representation accords to the integer number format (INT). The process data are entered in the default settings in the two's complement format (-1 accords to 0xFFFF).

Parameters

Detailed information on fieldbus-dependent parameterisation of the modules is contained in the chapter "Parameters of the *piconet*[®] I/O modules" of the following manuals:

- Profibus-DP
German: „*piconet*[®] for PROFIBUS-DP", D300775
English: „*piconet*[®] for PROFIBUS-DP", D300776
- DeviceNet
Not yet published
- CANopen
Not yet published

Diagnosis

Diagnostics via LEDs

Please read the description of the diagnostic LEDs in the event of local errors of the coupling and extension modules in Chapter 5 of this manual: Fieldbus-specific diagnostic indications via LEDs are described in the chapter "Error treatment and diagnostics" of the above mentioned manuals.

Diagnostics via software

Detailed information on fieldbus-dependent diagnostics of the modules is contained in the chapter "Error treatment and diagnostics" of the above mentioned manuals.

Data mapping



Note

Data mapping of the *piconet*[®] modules depends on the type of fieldbus.

For this, please refer to the mapping descriptions in chapter "Data mapping of the *piconet*[®] modules" of the respective bus-specific manuals.

Control and status byte

Process data operation

■ Control byte

The control byte is only visible, if the module is operated in the complex mode. It is contained in the output image and can be read or written.

Table 67:
Control byte

Bit	7	6	5	4	3	2	1	0
Name	RegAccess							

Table 68:
Control byte
description

Name	Description
RegAccess	0 = Register communication disabled (Process data operation)

■ Status byte

The status byte is only visible, if the module is operated in the complex mode. It is contained in the input image and can only be read.

Table 69:
Status byte

Bit	7	6	5	4	3	2	1	0
Name	RegAccess	Error	Limit value 2	Limit value 1	Over-range	Under-range		

Table 70:
Description of the
status byte

Name	Description
RegAccess	0 = Acknowledgement of process data operation
Error	General error bit – mode "0 to 20 mA" (R32, Bit 5 = 0): Bit 6 = 1 at measurement value > 21 mA – mode "4 to 20 mA" (R32, Bit 5 = 1): Bit 6 = 1 at measurement value < 3 mA or > 21 mA
Limit value 2	00 = Limit value not active
limit value 1	10 = Process data < Limit value 01 = Process data > Limit value 11 = Process data = Limit value
Over-range	– 0 = No over-range – 1 = Over-range → measuring range exceeded (> 21 mA), if "Overflow-Offset inactive" (R32, Bit 4 = 0); → measuring value > 20 mA, if "Overflow-Offset active" (R32, Bit 4 = 1)
Under-range	– 0 = No under-range 1 = Under-range → below measuring range (< 3 mA), if "Overflow-Offset inactive" (R32, Bit 4 = 0); → measuring value < 4 mA, if "Overflow-Offset active" (R32, Bit 4 = 1)

Register communication

During register communication measuring values cannot be transferred.

■ Control byte

The control byte is only visible, if the module is operated in the complex mode. It is contained in the output image and can be read or written.

Table 71:
Control byte in
register
communication

Bit	7	6	5	4	3	2	1	0
Name	RegAccess	R/W	Register number					

Table 72:
Control byte
description

Name	Description
RegAccess	1 = Register communication enabled
R/W	0 = Read 1 = Write
Register number	Number of the register that is to be read or written.

Register overview

Table 73:
Register overview
Sxxx-40A-x007

Register	Designation	Default value	Read/ Memory Write
R 0	ADC non-linearised value	Variable	R RAM
R 1 to R7	reserved	0000	R
R 8	Module type	0C28	R ROM
R 9	Software version	XXXX	R ROM
R 10	Multiplex shift register	0418	R ROM
R 11	Signal channels	0418	R ROM
R 12	Minimum data length	0098	R ROM
R 13	Data structure	0004	R ROM
R 14	reserved	0000	R
R 15	Alignment register	Variable	R/W RAM
R 16	Hardware version number	XXXX	R/W EEPROM
R 17	Hardware comparison: Offset	Specific	R/W EEPROM
R 18	Hardware comparison: Gain	Specific	R/W EEPROM
R 19	Manufacturer scaling: Offset	0000	R/W EEPROM
R 20	Manufacturer scaling: Gain	0080	R/W EEPROM
R 21 to R 30	reserved	0000	R/W
R 31	Codeword register	Variable	R/W RAM
R 32	Feature register	0012	R/W EEPROM

Register Designation		Default value (in hex)	Read/ Memory Write	
R 33	User offset	0000	R/W	EEPROM
R 34	User gain	0100	R/W	EEPROM
R 35	Limit value 1	0000	R/W	EEPROM
R 36	Limit value 2	0000	R/W	EEPROM
R 37	Filter register	3200	R/W	EEPROM
R 38	reserved	0000	R/W	
...	
R 63	reserved	0000	R/W	

Feature register (R32)

The basic settings of the module can be modified in the feature register. In order to write to the register, it is first required to reset the write protection in the code word register (R31).

Write the value [0x1235] to the register 31.



Note

Detailed information on register communication can be taken from Chapter 3: „Register communication“.

<i>Table 74: Feature register Sxxx-40A-x007</i>		Bit	Value Description
A <i>Default setting</i>	0	0	User scaling inactive A
		1	User scaling active
B <i>from software version "3" of the I/O board on SxxB-40A-x007 and software version "0" of the I/O board of SNNE-40A-x007</i>	1	0	Manufacturer scaling inactive
		1	Manufacturer scaling active A
	2	0	reserved (value = '0')
	3	0	Signed number representation inactive A (two's-complement representation → -1 = 0xFFFF)
		1	Signed number representation active (-1 = 0x8001)
	4	0	Overflow offset inactive
		1	Overflow offset active A
	5 B	0	0 to 20 mA mode A
		1	4 to 20 mA mode
	6 to 8	reserved	
	9	0	Limit value 1 inactive A
		1	Limit value 1 active (R35)
	10	0	Limit value 2 inactive A
		1	Limit value 2 active (R36)
	11 to 15	reserved	

Overflow offset

If this bit is set, the actual current value is monitored. The status byte indicates a possible over- / or under-range.

If this bit is not set, process data (> 0x7FFF oder > 0xFFFF) are monitored, depending on the manufacturer scaling. In this case, the status byte will also indicate a possible over- / or under-range.

User offset (R33) and user gain (R34)



Note

Adjustment of the user offset and gain of the module Sxxx-40A-x007 is identical to adjustment of module Sxxx-40A-x004: "User offset (R33)", Page 10-18 and "User gain (R34)", Page 10-19.

Filter register (R37)



Note

Assignment of the filter register of the module Sxxx-40A-x007 is identical to that of module Sxxx-40A-x004. For this, please also read "User offset (R33)", Page 10-20.

**Sxxx-40A-x009,
4-port analogue input module for Pt100 (RTD)**

The analogue input modules Sxxx-40A-x009 allow direct connection of resistance temperature detectors. The module is designed for connection of Pt100 resistors in 2, 3 or 4-wire technology.

Linear performance over the entire temperature range is accomplished via a micro-processor. The temperature range is freely selectable.

The module can also be used for resistance measurement. In this case, the measuring value is output in a range of 10 Ω to 1.2/5.0 k Ω with a resolution of 1/16 Ω (the internal resolution of the resistance value is 1/255 Ω).

In the temperature range of the Pt100 sensor in 4-wire technology, the module's setting is a resolution of 0.1 °C. Sensor malfunction, e.g. wire-break, is indicated via error LEDs.

This module is equipped with various features. The default settings have been selected in such a way that device configuration is usually not necessary. The input filters and thus the associated conversion times are adjustable within wide ranges and several data output formats are available. The input scaling may be modified if required; an automatic limit value monitoring function is also provided.

The module is either parameterised via the fieldbus or the additional configuration tool "I/O-ASSISTANT" via the configuration interface.

Figure 51:
SDPB-40A-x009,
SNNE-40A-0009

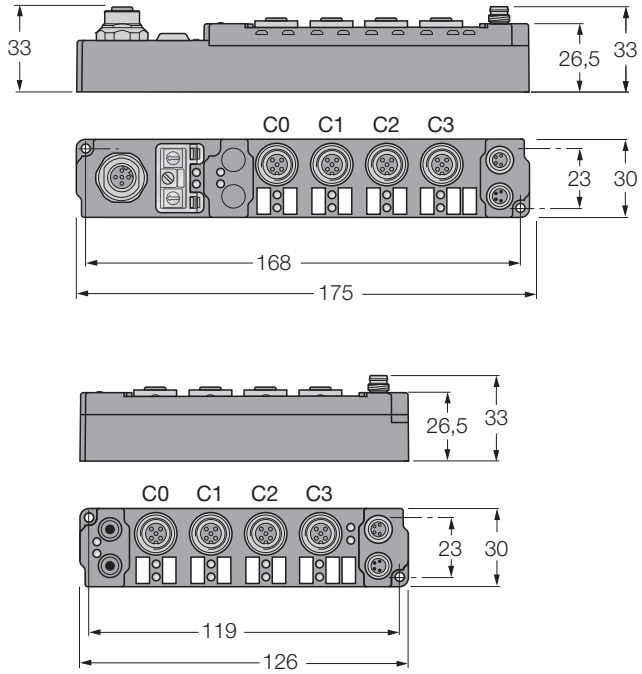

Technical data

Table 75:
Technical data

Designation	Sxxx-40A-x009
Voltage supply	
Operating voltage U_B	24 VDC (- 15 %/+ 20 %)
Load voltage U_L	24 VDC (- 15 %/+ 20 %)
Number of inputs	4
Sensor types	<ul style="list-style-type: none"> - Platinum sensors: Pt100, Pt200, Pt500, Pt1000, - Nickel sensors: Ni100, Ni120, Ni1000 - Resistance measurement (e.g. potentiometer)
Temperature ranges	<ul style="list-style-type: none"> - Platinum sensors: -200 to +850 °C - Nickel sensors: -0 to +250 °C
Resolution	0.1 °C per digit
Measuring current	typ. 0.5 mA
Conversion time	approx. 250 ms
Measuring error	$< \pm 1 \text{ °C}$
Current consumption Load voltage	300 mA typ. (additional current consumption of the module)
Input filter	5 versions, configurable
Sensor supply	from operating voltage U_B
Bytes in the process image	<ul style="list-style-type: none"> depending on mapping - <u>Compact</u>: 2 input data bytes per channel - <u>Complex</u>: 2 input and 2 output data bytes per channel + 1 status and 1 control byte per channel

Potential isolation	<ul style="list-style-type: none">- Channels / operating voltage 500 V_{eff}: no- Between the channels: no- Operating voltage/fieldbus: yes
---------------------	---

Wiring diagrams

- **4-wire technology** allows measurement and correction of measuring errors, which are caused by the ohmic resistance of cables and contacts.
- In the **3-wire mode**, line resistance is only measured in one direction to the resistance sensor and then multiplied by two. The in- and outgoing lines must have an almost identical ohmic resistance.
- Measuring errors, occurring in the **2-wire mode**, may vary greatly depending on temperature deltas and conductor cross sections.



Attention

The settings of one channel always affect all other channels of the module and are thus valid for the entire module.



Note

All module channels should be adjusted identically in order to prevent operating problems.



Note

Pin 5 (shield) is capacitively coupled to the conductive base surface of the *piconet*[®] module.

Figure 52:
Connection to the
M12

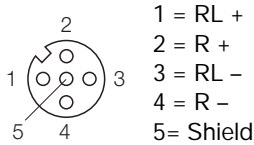

Connection types:

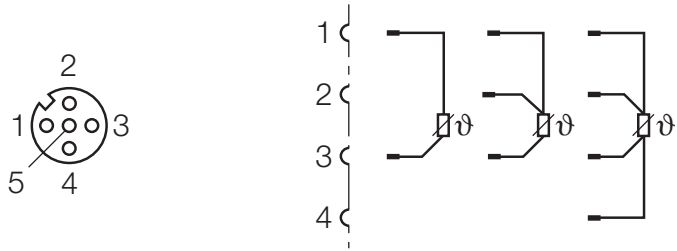

Supply voltage

U_B powers the fieldbus and the sensor electronics. It is galvanically isolated from U_L .

U_L is not needed for module function. An infeed is not needed.



Attention

Should you use U_L for a feed-through arrangement, please note that galvanic isolation is neutralized through feed-through of the load voltage when connecting a module without galvanic isolation between U_B and U_L (i.e. all digital modules).

Functions of the channel LEDs

Table 76:
Channel LED
indications

LED	Status	Meaning
R "Run"	Green	Data are transferred to the D/A converter.
	OFF	Presently, there is no data transfer.
E "Error"	red	Data transmission error Example: – Wire-break – Measuring value out of range – Temperature compensation out of valid range
	OFF	Error-free data transfer

Process data

Table 77:
Presentation of
process data

Process data		Measuring value
hex	decimal (integer)	
0xF63C	-2500	-250 °C
0xF830	-2000	-200 °C
0xFC18	-1000	-100 °C
0xFFFF	-1	-0,1 °C
0x0000	0	0,0 °C
0x0001	1	0,1 °C
0x03E8	1000	100 °C
0x07D0	2000	200 °C
0x1388	5000	500 °C
0x2134	8500	850 °C

Parameters

Detailed information on fieldbus-dependent parameterisation of the modules is contained in the chapter "Parameters of the *piconet*[®] I/O modules" of the following manuals:

- Profibus-DP
German: „*piconet*[®] for PROFIBUS-DP", D300775
English: „*piconet*[®] for PROFIBUS-DP", D300776
- DeviceNet
Not yet published
- CANopen
Not yet published

Diagnosis

Diagnostics via LEDs

Please read the description of the diagnostic LEDs in the event of local errors of the coupling and extension modules in Chapter 5 of this manual: Fieldbus-specific diagnostic indications via LEDs are described in the chapter "Error treatment and diagnostics" of the above mentioned manuals.

Diagnostics via software

Detailed information on fieldbus-dependent diagnostics of the modules is contained in the chapter "Error treatment and diagnostics" of the above mentioned manuals.

Data mapping



Note

Data mapping of the *piconet*[®] modules depends on the type of fieldbus.

For this, please refer to the mapping descriptions in chapter "Data mapping of the *piconet*[®] modules" of the respective bus-specific manuals.

Control and status byte

Process data operation

■ Control byte

The control byte is only visible, if the module is operated in the complex mode. It is contained in the output image and can be read or written.

Table 78:
Control byte

Bit	7	6	5	4	3	2	1	0
Name	RegAccess							

Table 79:
Control byte
description

Name	Description
RegAccess	0 = Register communication disabled (Process data operation)

■ Status byte

The status byte is only visible, if the module is operated in the complex mode. It is contained in the input image and can only be read.

Table 80:
Status byte

Bit	7	6	5	4	3	2	1	0
Name	RegAccess	Error reserved			reserved		Over-range	Under-range

Table 81:
Description of the
status byte

Name	Description
RegAccess	0 = Acknowledgement of process data operation
Error	General error bit
Over-range	$R > 400 \Omega$
Under-range	$R < 18 \Omega$

Register communication

During register communication measuring values cannot be transferred.

■ Control byte

The control byte is only visible, if the module is operated in the complex mode. It is contained in the output image and can be read or written.

<i>Table 82: Control byte in register communication</i>	Bit	7	6	5	4	3	2	1	0
	Name	RegAccess		R/W	Register number				

<i>Table 83: Control byte description</i>	Name	Description
	RegAccess	1 = Register communication enabled
	R/W	0 = Read 1 = Write
Register number	Number of the register that is to be read or written.	

■ Status byte

The status byte is only visible, if the module is operated in the complex mode. It is contained in the input image and can only be read.

<i>Table 84: Status byte</i>	Bit	7	6	5	4	3	2	1	0
	Name	RegAccess		R/W	Register number				

<i>Table 85: Control byte description</i>	Name	Description
	RegAccess	1 = Acknowledgement for register access
	R/W	0 = Read
Register number	Number of the register that is to be read.	

Register overview

Table 86:
Register overview
Sxxx-40A-x009

Register	Designation	Default value	Read/	Memory Write
R 0	ADC non-linearised value	Variable	R	RAM
R 1	ADC non-linearised value of the line	Variable	R	RAM
R 2 to R 5	reserved	0000	R	
R 6	Diagnostic register	Variable	R	RAM
R 7	reserved	0000	R	
R 8	Module type	0C82	R	ROM
R 9	Software version	XXXX	R	ROM
R 10	Multiplex shift register	0418	R	ROM
R 11	Signal channels	0418	R	ROM
R 12	Minimum data length	0098	R	ROM
R 13	Data structure	0000	R	ROM
R 14	reserved	0000	R	
R 15	Alignment register	Variable	R/W	RAM
R 16	Hardware version number	XXXX	R/W	SEEROM
R 17	Hardware comparison: Offset	Specific	R/W	SEEROM
R 18	Hardware comparison: Gain	Specific	R/W	SEEROM
R 19	Manufacturer scaling: Offset	0000	R/W	SEEROM
R 20	Manufacturer scaling: Gain	00A0	R/W	SEEROM
R 21	Offset register 2-wire connection mode	Specific	R/W	SEEROM

Register Designation		Default value (in hex)	Read/ Memory Write	
R 22	Offset register 3-wire connection mode	Specific	R/W	SEEROM
R 23 to R 30	reserved	0000	R/W	
R 31	Codeword register	Variable	R/W	RAM
R 32	Feature register	0102	R/W	SEEROM
R 33	User offset	0000	R/W	SEEROM
R 34	User gain	0100	R/W	SEEROM
R 35 and R 36	reserved	0000	R/W	
R 37	Filter register	0000	R/W	SEEROM
R 38 to R63	reserved	0000	R/W	

2-wire connection

A resistance can be directly measured via the 2-wire connection. The ohmic component of the line resistance can be measured and entered in register 21. In the 2-wire connection mode and with a shorted line resistance ($+R_L$; $-R_L$), it is required to write the ADC linearised value from register 1 into register 21.

Feature register (R32)

The basic settings of the module can be modified in the feature register.



Note

Selection of the 2, 3, or 4-wire measuring mode is read from the feature register of the first channel.

In order to write to the register, it is first required to reset the write protection in the code word register (R31).
Write the value [0x1235] to the register 31.

Default settings: 0x0010



Note

Detailed information on register communication can be taken from chapter 3 "Register communication".

Table 87:
Feature register
Sxxx-40A-x009

A Default
setting

Bit	Value	Description
0	0	User scaling inactive A
	1	User scaling active
1	0	Manufacturer scaling inactive
	1	Manufacturer scaling active A
2	0	reserved
3	0	Signed number representation inactive A (two's-complement representation → -1 = 0xFFFF)
	1	Signed number representation active
4	0	Hide Siemens additional bits A
	1	Show Siemens additional bits Diagnostic data (Page 10-51) are written to the process data (Bit 0-2).
5 and 6		reserved

	Bit	Value	Description
A Default setting	7	0	Manual filter adjustment in R 37 Disable AA
		1	Activate manual filter adjustment in R 37
B Valid from firmware version „2“ of the module SxxB-40A-x007 and from firmware version "0" of the module SNNE-40A-0009	8	0	De-activate over-range protection
		1	Activate over-range protection A If the temperature of 850 °C is exceeded, the status bits are set accordingly and the output value is limited to 850 °C.
	10 and 9	00	4-wire connection activated A
		01	3-wire connection activated B
		10	2-wire connection activated
	11		reserved
15, 14, 13, 12		0x0000	Pt100 -200 °C to 850 °C
		0x0001	Ni100 -60 °C to 250 °C
		0x0002	Pt1000 -200 °C to 850 °C
		0x0003	Pt500 -200 °C to 850 °C
		0x0004	Pt200 -200 °C to 850 °C
		0x0005	Ni1000 -200 °C to 850 °C
		0x0006	Ni120 -80 °C to 320 °C
		0x0007	RSNE1000 Nickel 1000: Special temperature curve of the company Siemens
		0x000E	Ohm 10 to 5000 Ω
		0x000F	Ohm 10 to 1200 Ω

Scaling range (measuring range 10 - 5000 Ohm)

Pre-conditions:

- Manufacturer scaling active
- User scaling active
- Output in Ohm

*Table 88:
Scaling
example*

Settings in register 34	Ohm/Digit
0x0500	0,100
0x0400	0,125
0x0200	0,250
0x0100	0,500
0x0080	1,000

Diagnostic information in the process data when using a Siemens controller type S5

If the parameter "Show Siemens additional bits" (R32, Bit 4) is activated, then bits 0...2 of the process data are used for status evaluation.

The process date is shown in bits 15-3, with bit 15 as the sign bit.

Table 89:
Process data
diagnostics

Bits	Name	Description
0	Overflow	0 = measuring value in valid range 1 = measuring value overflow
1	Error	0 = no error 1 = error
2	-	reserved
14 to 3	Measuring value	Process date
15	Sign	0 = positive sign 1 = negative sign

User offset (R33) and user gain (R34)



Note

The adjustment of the user offset and gain of the module Sxxx-40A-x009 accords to adjustment of module Sxxx-40A-x005: "User offset (R33)", Page 10-18 and "User gain (R34)", Page 10-19.

Filter register (R37)

The filter time of the A/D converter can be modified in the filter register. In order to write to the register, it is first required to reset the write protection in the code word register.

The conversion time of the A/D converter changes with the filter time. Both values correlate directly.

Filter settings always apply to all channels and are set in the first register of channel 1. The settings will only be activated after a power cycle (re-start).

Default 0x0000

Figure 53:
Filter register

Value (in hex)	Filter First Notch [Hz]	Conversion time
0000	25	200 ms
0050	100	70 ms
00A0	50	120 ms
140	25	200 ms
280	12,5	400 ms

Sxxx-40A-x004, 4-port analogue input module for thermoelements

The analogue input modules Sxxx-40A-x004 allow direct connection of thermoelements.

The module is designed for connection of thermoelement sensors in 2-wire technology. Linear performance over the entire temperature range is accomplished via a micro-processor. The temperature range is freely selectable.

The module can also be used for millivolt measurement.

The module's standard setting is: a resolution of 0.1 °C in the temperature range of type K sensors.

Sensor malfunction, e.g. wire-break, is indicated via error LEDs. Cold reference compensation is accomplished via temperature measurement in the connector. Thus it is possible to connect standard extension cables.

This module is equipped with various features. The default settings have been selected in such a way that device configuration is usually not necessary. The input filters and thus the associated conversion times are adjustable within wide ranges and several data output formats are available. The input scaling may be modified if required; an automatic limit value monitoring function is also provided.

The module is either parameterised via the fieldbus or the additional configuration tool "I/O-ASSISTANT" via the configuration interface.

Figure 54:
SDPB-40A-x004,
SNNE-40A-0004

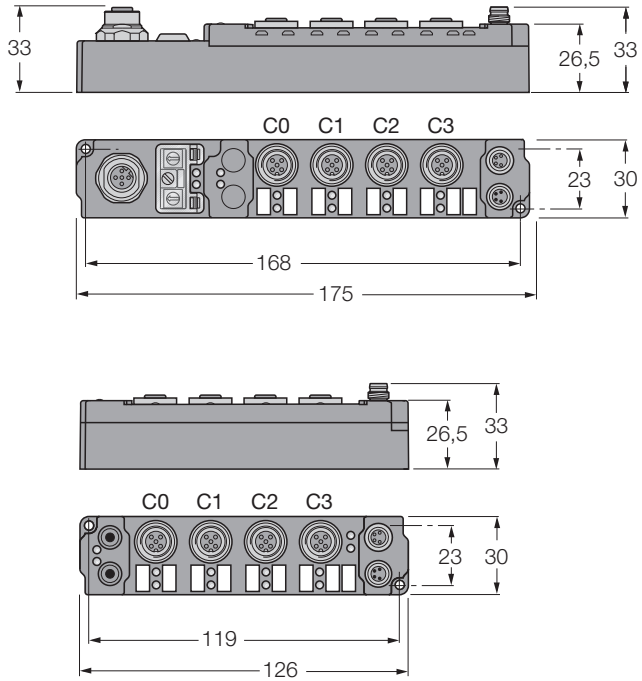

Technical data

*Table 90:
Technical data*

Designation	Sxxx-40A-x004
Voltage supply	
Operating voltage U_B	24 VDC (- 15 %/+ 20 %)
Load voltage U_L	24 VDC (- 15 %/+ 20 %)
Number of inputs	4
Sensor types	- Types J, K, L, B, E, N, R, S, T, U (Default: type K), - mV measurement
Temperature range	Sensor-dependent; Default: Type K, -100 to 1370 °C
Resolution	0.1 °C per digit
Measuring current	typ. 0.5 mA
Conversion time	approx. 250 ms
Measuring error	< ± 0,5% of final measuring value
Current consumption Load voltage	300 mA typ. (additional current consumption of the module)
Input filter	5 versions, configurable
Cold reference point compensation	Externally via compensation connector "WAS5 Thermo". Ident. no.: 6824260
Sensor supply	from load voltage U_L
Bytes in the process image	depending on mapping - Compact: 2 input data bytes per channel - Complex: 2 input and 2 output data bytes per channel + 1 status and 1 control byte per channel

Potential isolation	<ul style="list-style-type: none">- Channels/Operating voltage 500 V_{eff}: no- Between the channels: no- Operating voltage/fieldbus: yes
---------------------	---

Wiring diagrams

All modules feature external temperature compensation. This means that temperature compensation is carried out via the connector ("WAS5-Thermo"- Thermoelement connector with integrated cold reference point compensation), ident.-no. 6824260) directly at the connection point. This provides a significantly more precise temperature measuring result.



Note

Temperature compensation can also be carried out remotely. For this it is required to connect a Pt100 between pin 1 and 3. The longer the cable, the more significant the measured error depending on the length of the cable, power loss and interference.



Note

Pin 5 (shield) is capacitively coupled to the conductive base surface of the *piconet*[®] module.

Figure 55:
Connection to the
M12

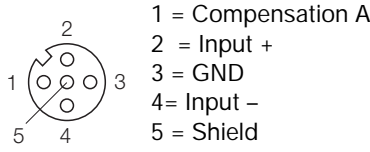

Connection types:

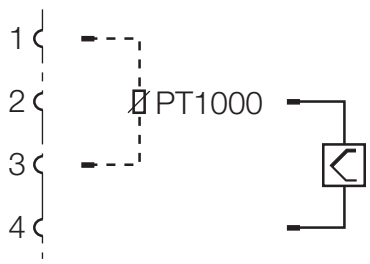
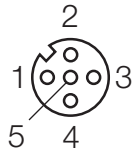

Supply voltage

U_B powers the fieldbus and the sensor electronics. It is galvanically isolated from U_L .

U_L is not needed for module function. An infeed is not needed.



Attention

Should you use U_L for a feed-through arrangement, please note that galvanic isolation is neutralized through feed-through of the load voltage when connecting a module without galvanic isolation between U_B and U_L (i.e. all digital modules).

Functions of the channel LEDs

Table 91:
Channel LED
indications

LED	Status	Meaning
R "Run"	Green	Data are transferred to the D/A converter.
	OFF	Presently, there is no data transfer.
E "Error"	red	Data transmission error Example: – Wire-break – Measuring value out of range – Temperature compensation out of valid range
	OFF	Error-free data transfer

Function principle

Thermoelements belong to category of active measuring sensors. The thermo-electrical effect is used for measurement (Seebeck, Peltier, Thomson).

If two electrical conductors of different material (e.g. iron - Konstantan) meet, a charge shift will occur at the contact surface. A contact voltage is induced which is a correlating function of the temperature. This thermo-voltage is both a function of the measuring temperature T as well as the comparator voltage T_v at the connection contacts of the thermoelement.

Since the coefficient is determined at a reference temperature of $0\text{ }^{\circ}\text{C}$, the influence of the reference temperature must be compensated. For this, the reference temperature is converted into a thermoelement-specific reference voltage and then added to the measured thermo-voltage. The temperature is then determined via the resulting voltage and the correlating temperature curve.

Figure 56:
Block diagram

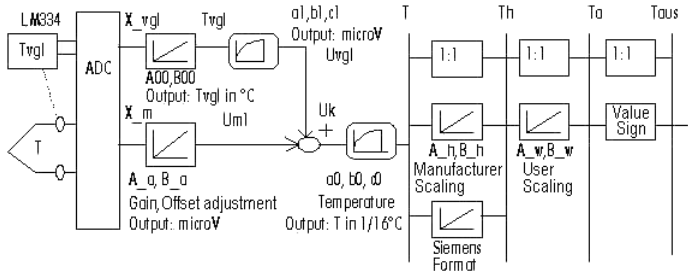

Temperatures are output as 1/10 °C (1 digit = 0.1 °C). A wire-break condition, i.e. a missing cold junction compensation sensor, is indicated and signalled via the error LED.

Process data output format

*Table 92:
Process data*

Process data (hex)	Process data - decimal (integer)	Measuring value
0xF63C	-2500	-250 °C
0xF830	-2000	-200 °C
0xFC18	-1000	-100 °C
0xFFFF	-1	-0,1 °C
0x0000	0	0,0 °C
0x0001	1	0,1 °C
0x02E8	1000	100 °C
0x07D0	2000	200 °C
0x1388	5000	500 °C
0x2134	8500	850 °C

Parameters

Detailed information on fieldbus-dependent parameterisation of the modules is contained in the chapter "Parameters of the *piconet*[®] I/O modules" of the following manuals:

- Profibus-DP
German: „*piconet*[®] for PROFIBUS-DP", D300775
English: „*piconet*[®] for PROFIBUS-DP", D300776
- DeviceNet
Not yet published
- CANopen
Not yet published

Diagnosis

Diagnostics via LEDs

Please read the description of the diagnostic LEDs in the event of local errors of the coupling and extension modules in Chapter 5 of this manual: Fieldbus-specific diagnostic indications via LEDs are described in the chapter "Error treatment and diagnostics" of the above mentioned manuals.

Diagnostics via software

Detailed information on fieldbus-dependent diagnostics of the modules is contained in the chapter "Error treatment and diagnostics" of the above mentioned manuals.

Data mapping



Note

Data mapping of the *piconet*[®] modules depends on the type of fieldbus.

For this, please refer to the mapping descriptions in chapter "Data mapping of the *piconet*[®] modules" of the respective bus-specific manuals.

Control and status byte

Process data operation

■ Control byte

The control byte is only visible, if the module is operated in the complex mode.

It is contained in the output image and can be read or written.

Table 93:
Control byte

Bit	7	6	5	4	3	2	1	0
Name	RegAccess	reserved						

Table 94:
Control byte
description

Name	Description
RegAccess	0 = Register communication disabled (Process data operation)

■ Status byte

The status byte is only visible, if the module is operated in the complex mode.

It is contained in the input image and can only be read.

Table 95:
Status byte

Bit	7	6	5	4	3	2	1	0
Name	RegAccess	Error	-	-	No Cold Junction	Internal Error	Over- range	Under- range

*Table 96:
Description of the
status byte*

Name	Description
RegAccess	0 = Acknowledgement of process data operation
Error	General error bit
No Cold Junction	Loss of the cold junction in the connector: If the cold junction is outside the range of -50 to +100 °C, an error is indicated
Internal Error	The analogue component of the module is defect
Over-range	Wire-break
Under-range	Below minimum value of the selected thermoelement (feature register: bit 12 to bit 15)

Register communication

During register communication measuring values cannot be transferred.

■ Control byte

The control byte is only visible, if the module is operated in the complex mode. It is contained in the output image and can be read or written.

*Table 97:
Control byte in
register
communication*

Bit	7	6	5	4	3	2	1	0
Name	RegAccess	R/W	Register number					

*Table 98:
Control byte
description*

Name	Description
RegAccess	- 1 = Register communication enabled
R/W	- 0 = Read - 1 = Write
Register number	- Number of the register that is to be read or written.

■ Status byte

The status byte is only visible, if the module is operated in the complex mode. It is contained in the input image and can only be read.

Table 99:
Status byte

Bit	7	6	5	4	3	2	1	0
Name	RegAccess	R/W	Register number					

Table 100:
Control byte
description

Name	Description
RegAccess	1 = Acknowledgement for register access
R/W	0 = Read
Register number	Number of the register that is to be read.

Register overview

*Table 101:
Register overview
Sxxx-40A-x004*

Register	Designation	Default value (in hex)	Read/ Memory Write	
R 0	ADC non-linearised value	Variable	R	RAM
R 1	COMP- non-linearised value	Variable	R	RAM
R2	TCOMP in 1/16 °C	Variable	R	RAM
R3 to R5	reserved	0000	R	
R 6	Diagnostic register	Variable	R	RAM
R 7	reserved	0000	R	
R 8	Module type	0CF0	R	ROM
R 9	Software version	XXXX	R	ROM
R 10	Multiplex shift register	0418	R	ROM
R 11	Signal channels	0418	R	ROM
R 12	Minimum data length	0098	R	ROM
R 13	Data structure	0000	R	ROM
R 14	reserved	0000	R	
R 15	Alignment register	Variable	R/W	RAM
R 16	Hardware version number	XXXX	R/W	SEEROM
R 17	Hardware comparison: Offset	Specific	R/W	SEEROM
R 18	Hardware comparison: Gain	Specific	R/W	SEEROM
R 19	Manufacturer scaling: Offset	0000	R/W	SEEROM
R 20	Manufacturer scaling: Gain	00A0	R/W	SEEROM

Register Designation		Default value (in hex)	Read/ Memory Write	
R 21	Hardware comparison: Reference temperature	Specific	R/W	SEEROM
R22	reserved	0000	R/W	
...	
R 30	reserved	0000	R/W	
R 31	Codeword register	Variable	R/W	RAM
R 32	Feature register	1002	R/W	SEEROM
R 33	User offset	0000	R/W	SEEROM
R 34	User gain	0100	R/W	SEEROM
R 35	reserved	0000	R/W	
R 36	reserved	0000	R/W	
R 37	Filter register	0000	R/W	SEEROM
R 38 to R 63	reserved	0000	R/W	

Feature register (R32)

The basic settings of the module can be modified in the feature register. In order to write to the register, it is first required to reset the write protection in the code word register (R31). Write the value [0x1235] to the register 31.



Note

Detailed information on register communication can be taken from chapter 3 "Register communication".

Table 102:
Feature register
Sxxx-40A-x004

A Default
setting

Bit	Value	Description
0	0	User scaling inactive A
	1	User scaling active
1	0	Manufacturer scaling inactive
	1	Manufacturer scaling active A
2	0	reserved (value = '0')
3	0	Signed number representation inactive A (two's-complement representation → -1 = 0xFFFF)
	1	Signed number representation active
4	0	Hide Siemens additional bits A
	1	Show Siemens additional bits Diagnostic data are written to the process data (bits 0-2).
5	0	Manual filter adjustment in R 37 disabled A
	1	Activate manual filter adjustment in R 37
6 and 7	reserved	
8	0	Reference temperature ON A
	1	Reference temperature OFF

Bit	Value	Description		
9 and 10	reserved			
11	0	One measuring point per channel A : Do not accept reference point of first channel for all other channels		
	1	Channel 1 for all channels: Accept reference point of first channel for all other channels		
15, 14, 13, 12		Type	Min. value	Max. value
	0x0000	Thermocouple type L	-100 °C	900 °C
	0x0001	Thermocouple type K A	-100 °C	1370 °C
	0x0002	Thermocouple type J	-100 °C	1000 °C
	0x0003	Thermocouple type E	-100 °C	800 °C
	0x0004	Thermocouple type T	-100 °C	400 °C
	0x0005	Thermocouple type N	-100 °C	1300 °C
	0x0006	Thermocouple type U	-100 °C	600 °C
	0x0007	Thermocouple type B	600 °C	1800 °C
	0x0008	Thermocouple type R	0 °C	1700 °C
	0x0009	Thermocouple type S	0 °C	1700 °C
	0x000D	Millivolt measurement	- 30 mV	+ 30 mV
	0x000E	Millivolt measurement	- 60 mV	+ 60 mV
	0x000F	Millivolt measurement	- 120 mV	+120 mV

User scaling

In order to adjust the module to Fahrenheit, the following formula must be used and the user register must be written.

Formula:

$$^{\circ}\text{F} = 9/5 \times ^{\circ}\text{C} + 32$$

To adjust scaling to 1/10 $^{\circ}\text{F}$, the constant part (offset) is multiplied by 10.

That means:

- For the offset
 $32 * 10 = 320$
- For the gain
 $(9/5 * 10/16 * 256) = 288$

Required register settings:

- Register 31: Set code word = 0x1235
- Register 32: De-activate manufacturer scaling
- Register 32: Activate user scaling
- Register 33: User offset = 320_{dec}
- Register 34: User gain = 288_{dec}

The scaling modifications can be set individually for each channel and are immediately valid.

Diagnostic information in the process data when using a Siemens controller type S5

If the parameter "Show Siemens additional bits" (R32, Bit 4) is activated, then bits 0...2 of the process data are used for status evaluation.

The process date is shown in bits 15-3, with bit 15 as the sign bit.

Table 103:
Process data
diagnostics

Bits	Name	Description
0	Overflow	0 = measuring value in valid range 1 = measuring value overflow
1	Error	0 = no error 1 = error
2	-	reserved
14 to 3	Measuring value	Process date
15	Sign	0 = positive sign 1 = negative sign

User offset (R33) and user gain (R34)



Note

The adjustment of the user offset and gain of the module Sxxx-40A-x009 accords to adjustment of module Sxxx-40A-x005: "User offset (R33)", Page 10-18 and "User gain (R34)", Page 10-19.

Filter register (R37)



Note

Configuration of the filter register of the module Sxxx-40A-x004 is identical to that of module Sxxx-40A-x009.
For this, please also read "Filter register (R37)", Page 10-52.

11 Analogue output modules

Type overview	2
Sxxx-04A-x007, 4-port analogue output module, ± 10 V	3
Technical data	5
Wiring diagrams	6
Functions of the channel LEDs	6
Process data	7
Parameters	8
Diagnosis	8
– Diagnostics via LEDs	8
– Diagnostics via software	8
Data mapping	8
Control and status byte	9
– Process data operation	9
– Register communication	10
Register overview	11
– Feature register (R32)	12
– User offset (R33)	13
– User gain (R34)	14
Sxxx-04A-x009, 4-port analogue output module, 0/4 to 20 mA	15
Technical data	17
Wiring diagrams	18
Functions of the channel LEDs	18
Process data	19
Parameters	20
Diagnosis	20
– Diagnostics via LEDs	20
– Diagnostics via software	20
Data mapping	20
Control and status byte	21
– Register overview	22
– Feature register (R32)	24
– User offset (R33)	26
– User gain (R34)	26

Type overview

<i>Table 104: Type overview analogue output modules</i>	Sxxx-04A-x00x	Description	Connectio n technology
	Sxxx-04A- x007 , Page 11-3	– 4 analogue outputs -10 V to +10 V	M12
	Sxxx-40A- x009 , Page 11-15	– 4 analogue outputs 0/4 to 20 mA	M12

Sxxx-04A-x007, 4-port analogue output module, ± 10 V

The analogue output modules, type Sxxx-04A-x007, generate an analogue output signal of ± 10 V and come as stand-alone or extension module.

The 4 output channels have a common ground with the 24 VDC supply. The outputs are powered via the operating voltage. The provided load voltage (freely selectable up to 30 VDC) is used to supply connected actuators.

The resolution is specified with 16 bits, with an accuracy of $< \pm 0.1$ % of the upper measuring range value.

The outputs can be adjusted either via the fieldbus or the separately available configuration tool "I/O-ASSISTANT" via the configuration interface. The settings made are stored in the module.

Figure 57:
SDPB-04A-x007,
SNNE-04A-x007

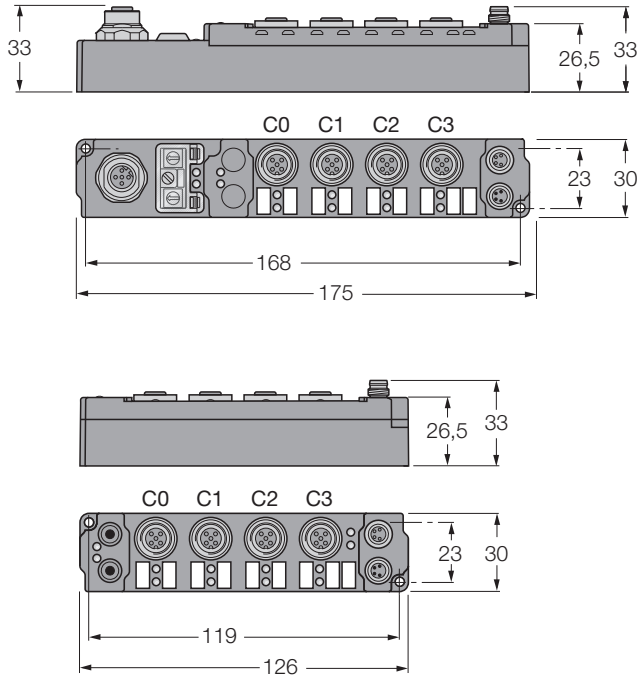

Technical dataTable 105:
Technical data

Designation	Sxxx-04A-x007
Voltage supply	
Operating voltage U_B	24 VDC (-15 %/+20 %)
Load voltage U_L	24 VDC (-15 %/+20 %)
Number of outputs	4
Output range (nominal value)	-10/0...10 V
Load	> 5 k Ω
Resolution	16 bits
Conversion time	< 1 ms
Relative measuring error	< $\pm 0,1\%$ of final measuring value
Actuator supply	from load voltage U_L
Bytes in the process image	depending on mapping – Compact: 2 output data bytes per channel – Complex: 2 input and 2 output data bytes per channel + 1 status and 1 control byte per channel
Potential isolation	– Channels/Operating voltage: yes – Between the channels: no – Operating voltage/fieldbus: depending on bus system

Wiring diagrams

The actuator is connected via output +/- . An actuator can be operated/supplied optionally with 24 VDC.

In order to ensure effective discharge of the immission, the ground surface must be conductive and feature low-resistance earthing.



Note

Pin 5 (shield) is capacitively coupled with the base surface of the *piconet*[®] module.

Figure 58:
Connection to the
M12

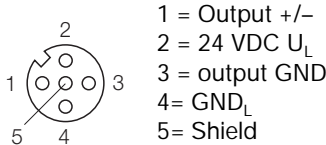

Connection types:

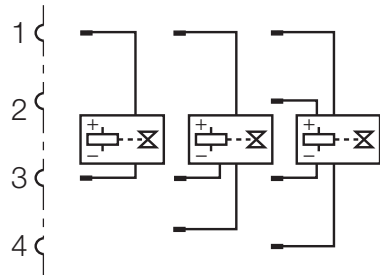
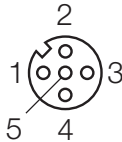

Functions of the channel LEDs

Table 106:
LED indications

LED	Status	Meaning
R "Run"	Green	Data are transferred to the D/A converter.
	OFF	Presently, there is no data transfer.
E "Error"		No function. Illuminates shortly during power-up.

Process data

The analogue output module generates output signals in a range of -10 to +10 V. The output voltage is output by the module with a resolution of up to 16 bits.

*Table 107:
Presentation of
process data*

Process data		Measuring value
hex	Decimal	
8001	-32767	-10 V
C001	-16383	- 5 V
0000	0	0
3FFF	16383	5 V
7FFF	32767	10 V

Data representation accords to the integer number format (INT). The process data are entered in the default settings in the two's complement format (-1 = 0xFFFF).

Parameters

Detailed information on fieldbus-dependent parameterisation of the modules is contained in the chapter "Parameters of the *piconet*[®] I/O modules" of the following manuals:

- Profibus-DP
German: „*piconet*[®] for PROFIBUS-DP“, D300775
English: „*piconet*[®] for PROFIBUS-DP“, D300776
- DeviceNet
Not yet published
- CANopen
Not yet published

Diagnosis

Diagnostics via LEDs

Please read the description of the diagnostic LEDs in the event of local errors of the coupling and extension modules in Chapter 5 of this manual: Fieldbus-specific diagnostic indications via LEDs are described in the chapter "Error treatment and diagnostics" of the above mentioned manuals.

Diagnostics via software

Detailed information on fieldbus-dependent diagnostics of the modules is contained in the chapter "Error treatment and diagnostics" of the above mentioned manuals.

Data mapping



Note

Data mapping of the *piconet*[®] modules depends on the type of fieldbus.

For this, please refer to the mapping descriptions in chapter "Data mapping of the *piconet*[®] modules" of the respective bus-specific manuals.

Control and status byte

Process data operation

■ Control byte

The control byte is only visible, if the module is operated in the complex mode. It is contained in the output image and can be read or written.

<i>Table 108: Control byte</i>	Bit	7	6	5	4	3	2	1	0
	Name	RegAccess	reserved						

<i>Table 109: Control byte description</i>	Name	Description
		RegAccess

■ Status byte

The status byte is only visible, if the module is operated in the complex mode. It is contained in the input image and can only be read.

<i>Table 110: Status byte</i>	Bit	7	6	5	4	3	2	1	0
	Name	RegAccess	reserved						

<i>Table 111: Description of the status byte</i>	Name	Description
		RegAccess

Register communication

During register communication measuring values cannot be transferred.

■ Control byte

The control byte is only visible, if the module is operated in the complex mode. It is contained in the output image and can be read or written.

Bit	7	6	5	4	3	2	1	0
Name	RegAccess	R/W	Register number					

Table 112:
Control byte in
register
communication

Name	Description
RegAccess	1 = Register communication enabled
R/W	0 = Read 1 = Write
Register number	Number of the register that is to be read or written.

■ Status byte

The status byte is only visible, if the module is operated in the complex mode. It is contained in the input image and can only be read.

Bit	7	6	5	4	3	2	1	0
Name	RegAccess	R/W	Register number					

Table 114:
Status byte

Name	Description
RegAccess	1 = Acknowledgement for register access
R/W	0 = Read
Register number	Number of the register that is to be read.

Register overview

Table 116:
Register overview
Sxxx-04A-x007

Register	Designation	Default value (in hex)	Read/ Memory Write	
R 0 to R 4	reserved	0000	R	
R 5	DAC non-linearised value	Variable	R	RAM
R 6 and R 7	reserved	0000	R	
R 8	Module type	1024	R	ROM
R 9	Software version	XXXX	R	ROM
R 10	Multiplex shift register	0418	R	ROM
R 11	Signal channels	0418	R	ROM
R 12	Minimum data length	9800	R	ROM
R 13	Data structure	0004	R	ROM
R 14	reserved	0000	R	
R 15	Alignment register	Variable	R/W	RAM
R 16	Hardware version number	XXXX	R/W	SEEROM
R 17	Hardware comparison: Offset	Specific	R/W	SEEROM
R 18	Hardware comparison: Gain	Specific	R/W	SEEROM
R 19	Manufacturer scaling: Offset	0000	R/W	SEEROM
R 20	Manufacturer scaling: Gain	0100	R/W	SEEROM
R 21 to R 30	reserved	0000	R	

Register Designation		Default value (in hex)	Read/ Memory Write	
R 31	Codeword register	Variable	R/W	RAM
R 32	Feature register	0000	R/W	SEEROM
R 33	User offset	0000	R/W	SEEROM
R 34	User gain	0100	R/W	SEEROM
R 35	User switch-on value	0000	R/W	SEEROM
R 36 to R 63	reserved	0000	R/W	

Feature register (R32)

The basic settings of the module can be modified in the feature register. In order to write to the register, it is first required to reset the write protection in the code word register.

Table 117:
Feature register
Sxxx-04A-x007

A Default setting

Bit	Value	Description
0	0	User scaling inactive A
	1	User scaling active
1	0	Manufacturer scaling inactive A
	1	Manufacturer scaling active
2	0	Watchdog timer active A
	1	Watchdog timer inactive
3 to 7		reserved
8	0	Manufacturer switch-on value [0] A
	1	User switch-on value R35
9 to 15		reserved

Explanation of the watch-dog timer

The ex factory settings include an active watch-dog timer. In case of a watchdog overflow, either the manufacturer or the user switch-on value is output via the module output.

User offset (R33)

Register 33 is used to adjust the user offset. The following table shows the assignment of register value to offset:

<i>Table 118: User offset</i>	Value R33 (hex)	Offset in % of the measuring value
A <i>Default setting</i>	8000	- 50%

	C000	- 25%

	FFFF	-100/65535%= - 0.0015269
	0000 A	0%
	0001	+100/65535%= +0.0015269

	3FFF	+ 25%

	7FFF	+ 50%

User gain (R34)

To calculate the user gain include the following gain factors:

Table 119:
User gain

A Default
setting

Value R34 (hex)	Gain factor
8000	x 8
...	...
0400	x 4
...	...
0200	x 2
...	...
0100 A	x 1
...	...
0080	x 0,5
...	...
0040	x 0,25
...	...
0020	x 0,125
...	...
0010	x 0.0625

**Sxxx-04A-x009,
4-port analogue output module, 0/4 to 20 mA**

The analogue output modules, type Sxxx-04A-x009, generate an analogue output signal of 0/4 to 20 mA and come as stand-alone or extension module.

The four channels feature galvanic isolation from the supply voltage and a common ground.

The resolution is pre-set (default) to 15 bits, but can also be configured for 16 bits.

The module operates with an accuracy of $< \pm 0.1 \%$ of the upper measuring range value.

The outputs can be adjusted either via the fieldbus or the separately available configuration tool "I/O-ASSISTANT" via the configuration interface. The settings made are stored in the module.

Figure 59:
SDPB-04A-x009,
SNNE-04A-x009

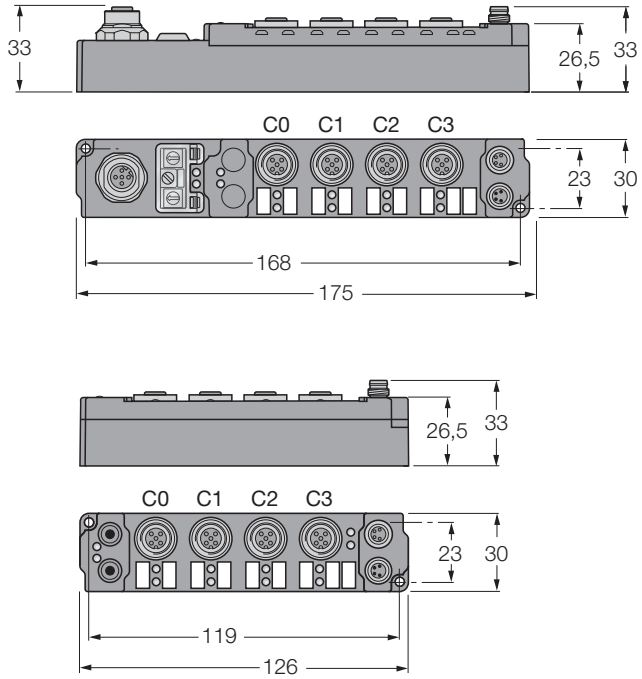

Technical data

Table 120:
Technical data

Designation	Sxxx-04A-x009
Voltage supply	
Operating voltage U_B	24 VDC (-15 %/+20 %)
Load voltage U_L	24 VDC (-15 %/+20 %)
Number of outputs	4
Output range (nominal value)	0/4 to 20 mA
Load	< 500 Ω
Resolution	15 bits, configurable to 16 bits
Conversion time	< 4 ms
Accuracy	< $\pm 0.1\%$ of final measuring value
Actuator supply	from load voltage U_L
Bytes in the process image	depending on mapping – Compact: 2 output data bytes per channel – Complex: 2 input and 2 output data bytes per channel + 1 status and 1 control byte per channel
Potential isolation	– Channels/Operating voltage: yes – Between the channels: no – Operating voltage/fieldbus: depending on bus system

Wiring diagrams

The actuator is connected via output +/- . An actuator can be operated/supplied optionally with 24 VDC.

In order to ensure effective discharge, the ground surface must be conductive and feature low-resistance earthing.



Note

Pin 5 (shield) is capacitively coupled with the base surface of the *piconet*[®] module.

Figure 60:
Connection to the
M12

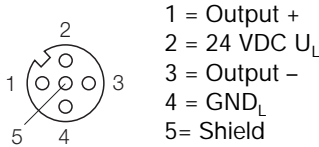

Connection types:

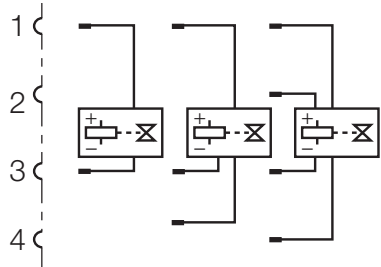
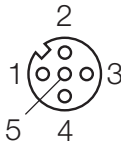

Functions of the channel LEDs

Table 121:
LED indications

LED	Status	Meaning
R "Run"	Green	Data are transferred to the D/A converter.
	OFF	Presently, there is no data transfer.
E "Error"		No function. Illuminates shortly during power-up.

Process data

The analogue output module generates output signals in a range of 0 to 20 mA. The output current is output by the module with a resolution of up to 16 bits.

Table 122:
Presentation of
process data

Process data		Measuring value
hex	Decimal	
0x0000	0	0 mA
0x3FFF	16383	10 mA
0x7FFF	32767	20 mA

**Note**

From software version "3" on of the I/O board of the stand-alone modules and software version "0" of the I/O board of the extension modules, the range of 4 to 20 mA can be set in register 32 (bit 5 = 1). This setting in feature register (R32) can be set separately for each channel.

Table 123:
Adjustment of the
measuring values
"4 to 20 mA"

Process data		Measuring value
hex	Decimal	
0000	0	4 mA
3FFF	16383	12 mA
7FFF	32767	20 mA

Parameters

Detailed information on fieldbus-dependent parameterisation of the modules is contained in the chapter "Parameters of the *piconet*[®] I/O modules" of the following manuals:

- Profibus-DP
German: „*piconet*[®] for PROFIBUS-DP“, D300775
English: „*piconet*[®] for PROFIBUS-DP“, D300776
- DeviceNet
Not yet published
- CANopen
Not yet published

Diagnosis

Diagnostics via LEDs

Please read the description of the diagnostic LEDs in the event of local errors of the coupling and extension modules in Chapter 5 of this manual: Fieldbus-specific diagnostic indications via LEDs are described in the chapter "Error treatment and diagnostics" of the above mentioned manuals.

Diagnostics via software

Detailed information on fieldbus-dependent diagnostics of the modules is contained in the chapter "Error treatment and diagnostics" of the above mentioned manuals.

Data mapping



Note

Data mapping of the *piconet*[®] modules depends on the type of fieldbus.

For this, please refer to the mapping descriptions in chapter "Data mapping of the *piconet*[®] modules" of the respective bus-specific manuals.

Control and status byte



Note

Control and status byte of the module Sxxx-04A-x009 are identical to those of module Sxxx-04A-x007.
Please also read „Control and status byte“, Page 11-9.

Register overview

Table 124:
Register overview
Sxxx-04A-x009

Register	Designation	Default value	Read/ Memory Write	
R 0 to R 4	reserved	0000	R	
R 5	DAC non-linearised value	Variable	R	RAM
R 6 and R 7	reserved	0000	R	
R 8	Module type	1010	R	ROM
R 9	Software version	XXXX	R	ROM
R 10	Multiplex shift register	0418	R	ROM
R 11	Signal channels	0418	R	ROM
R 12	Minimum data length	9800	R	ROM
R 13	Data structure	0004	R	ROM
R 14	reserved	0000	R	
R 15	Alignment register	Variable	R/W	RAM
R 16	Hardware version number	XXXX	R/W	EEPROM
R 17	Hardware comparison: Offset	Specific	R/W	EEPROM
R 18	Hardware comparison: Gain	Specific	R/W	EEPROM
R 19	Manufacturer scaling: Offset	0000	R/W	EEPROM
R 20	Manufacturer scaling: Gain	0200	R/W	EEPROM

Register Designation		Default value (in hex)	Read/ Memory Write	
R 21 to R 30	reserved	0000	R	
R 31	Codeword register	Variable	R/W	RAM
R 32	Feature register	0002	R/W	EEPROM
R 33	User offset	0000	R/W	EEPROM
R 34	User gain	0100	R/W	EEPROM
R35	User switch-on value	0000	R/W	EEPROM
R 36 to R 63	reserved	0000	R/W	

Feature register (R32)

The basic settings of the module can be modified in the feature register. In order to write to the register, it is first required to reset the write protection in the code word register.

Table 125:
Feature register
Sxxx-04A-x009
A Default
setting
B from software
version "2" on of
the I/O board
SxxB-04A-x009
and version "0"
of the I/O board
SNNE-04A-x009

Bit	Value	Description
0	0	User scaling inactive A
	1	User scaling active
1	0	Manufacturer scaling inactive
	1	Manufacturer scaling active A
2	0	Watchdog timer active A
	1	Watchdog timer inactive
3 and 4		reserved
5 B	0	Mode: 0 to 20 mA A
	1	Mode: 4 to 20 mA
6 and 7		reserved
8	0	Manufacturer switch-on value [0] A
	1	User switch-on value (substitute value, register 35)
9 to 15		reserved

Explanation of the watch-dog timer

The ex factory settings include an active watch-dog timer. In case of a watch-dog overflow, either the manufacturer or the user switch-on value is output as a substitute value via the module output.



Note

The standard output format 16 Bit Signed Integer is activated for compatibility reasons. The positive value range for 0 to 20 ranges from 0x0000 bis 0x7FFF. This accords to 15 bits. In order to use all 16 bits, manufacturer scaling must be de-activated.

User offset (R33)



Note

The adjustment of the user offset and gain of the module Sxxx-04A-x009 accords to adjustment of module Sxxx-04A-x007: „User offset (R33)“, Page 11-13 and „User gain (R34)“, Page 11-14.

User gain (R34)

To calculate the user gain include the following gain factors:

Table 126:
User gain

A Default
setting

Value R34 (hex)	Gain factor
8000	× 8
...	...
0400	× 4
...	...
0200 A	× 2
...	...
0100	× 1
...	...
0080	× 0,5
...	...
0040	× 0,25
...	...
0020	× 0,125
...	...
0010	× 0,0625



12 Technology modules

Type overview	4
Sxxx-10S-x001,	
1-channel incremental encoder interface	5
Technical data	7
Wiring diagram	8
Functions of the channel LEDs	8
Process data	9
Parameters	10
Diagnosis	10
– Diagnostics via LEDs	10
– Diagnostics via software	10
Data mapping	10
Control and status byte	11
– Process data operation	11
– Register communication	15
Register overview	16
– Data byte D2	17
Feature register (R32)	18
Sxxx-10S-x002,	
1-channel RS232 interface	20
Technical data	22
Wiring diagram	23
Functions of the channel LEDs	23
Parameters	23
Diagnosis	24
– Diagnostics via LEDs	24
– Diagnostics via software	24
Data mapping	24
Control and status byte	24
– Process data operation	24
– Examples	27
– Register communication	29
Register overview	30
– Diagnostic register (R6)	31
– Buffer size (R18)	32
– Baud rate register (R32)	32
– Data frame register (R33)	33
– Feature register (R34)	34

Data byte register (R35).....	35
Sxxx-10S-x004,	
1-channel RS485/422 interface.....	36
Technical data	38
Wiring diagram	39
Functions of the channel LEDs	39
Parameters	40
Diagnosis.....	40
– Diagnostics via LEDs	40
– Diagnostics via software	40
Data mapping	41
Control and status byte.....	41
Register overview	41
– Feature register (R34)	42
Sxxx-10S-x005,	
1-channel SSI interface	45
Technical data	47
Wiring diagram	48
Functions of the channel LEDs	48
Process data	48
Parameters	49
Diagnosis.....	49
– Diagnostics via LEDs	49
– Diagnostics via software	49
Data mapping	49
Control and status byte.....	50
– Process data operation	50
– Register communication	51
Register overview	53
Feature register (R32)	54
Baud rate register (R33)	55
Data length register (R34).....	56
Sxxx-0002D-x002,	
2-channel pulse width output 24 VDC/2.5 A.....	57
Technical data	59
Wiring diagram	60
Functions of the channel LEDs	60
Operating modes.....	61
– PWM Mode	61

- Frq-Cnt PWM mode66
- Frq-Cnt Pulse Mode67
- Cnt-Cnt-PWM Mode69
- Pulse width ratio in the process data70
- Output power (Derating).....71
- Parameters74
- Diagnosis74
 - Diagnostics via LEDs74
 - Diagnostics via software74
- Data mapping74
- Control and status byte.....75
 - Process data operation75
 - Register communication76
- Register overview of the PWM module78
- Feature register (R32)80

- Sxxx-0202D-x003,**
- Up/down counter, 24 VDC, 100 kHz 81**
 - Technical data83
 - Wiring diagram84
 - Meaning of the LEDs85
 - Function principle85
 - Internal functions86
 - Pulse mode86
 - Process data87
 - Parameters87
 - Diagnosis87
 - Diagnostics via LEDs87
 - Diagnostics via software87
 - Data mapping88
 - Control and status byte.....88
 - Process data operation88
 - Register communication90
 - Register overview92
 - Feature register (R32)94
 - Function register96

Type overview

Table 127:
Type overview
technology
modules

Module designation	Description	Connection technology
Sxxx-10S-x00x		
Sxxx-10S- x001 , Page 12-5	– 1-channel incremental encoder interface, 1 MHz	M12, M23
Sxxx-10S- x002 , Page 12-20	– 1-channel serial RS232 interface	M12
Sxxx-10S- x004 , Page 12-36	– 1-channel serial RS422/422 interface	M12
Sxxx-10S- x005 , Page 12-45	– 1-channel serial SSI interface	M23
Sxxx-xxxxD-x00x		
Sxxx-0002D- x002 , Page 12-57	2 digital pulse width outputs, 24 VDC, $I_{MAX} = 2.5 \text{ A}$	M12
Sxxx- 0202D-x003 , Page 12-81	Up/down counter, 24 VDC, 100 kHz	M12

Sxxx-10S-x001, 1-channel incremental encoder interface

The incremental encoder interface module Sxxx-10S-x001 allows connection of any 5 V **PNP**-incremental encoder to the fieldbus, or the *piconet*[®] system. A 16-bit counter with quadrature decoder as well as a 16-bit latch can be read, set or activated. Alongside the encoder inputs A, B, C, there is an additional latch input (24 V) as well as a gate input (24 V) available to inhibit the counter.

Additionally, the operating mode 16-bit up/down counter can be selected. In this mode, input A is the counter input and input B determines the counting direction.

A period duration measurement can also be implemented via the feature register. The period between two positive edges of the input signal A is determined with a resolution of 250 ns.

1, 2, 3, or 4-fold evaluation of the encoder signals A, B, C in simple or complementary form can be programmed via the fieldbus. The module comes as a 4-fold quadrature decoder with complementary evaluation of the encoder signals A, B and C.

If the encoder is equipped with an alarm output, it can be connected to the STATUS input of the module.

The encoder is powered via the module with the required voltage of 5 VDC.

The module is either parameterised via the fieldbus or the additional configuration tool "I/O-ASSISTANT" via the configuration interface. Parameters are stored permanently in the module, even in the event of a power failure.

Figure 61:
SDPB-10S-x001,
SNNE-10S-x001

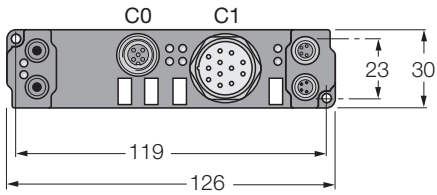
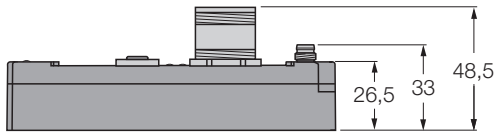
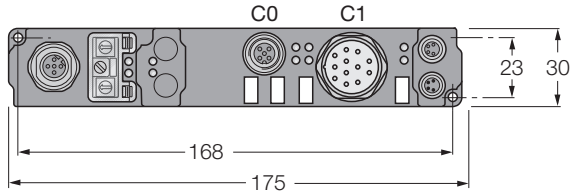
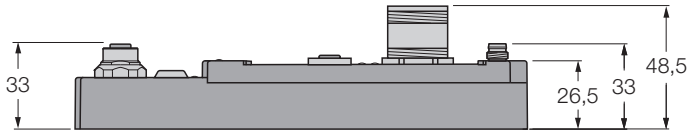

Technical data

Table 128:
Technical data
SxxB-10S-x005

Designation	SxxB-10S-x001
Voltage supply	
Operating voltage U_B	24 VDC (-15 %/+20 %)
Load voltage U_L	24 VDC (-15 %/+20 %)
Number of channels	1
Encoder connection	M23 threaded connectors, 12-pole
Gate/Latch connection	M12 threaded connectors
Sensor supply	via operating voltage, max. 0.5 A, common short-circuit protection
Counter	16 bits binary
Encoder supply	5 VDC
Limit frequency	1 MHz (4-fold evaluation)
Quadrature decoder	1, 2, 4-fold evaluation
Zero pulse latch	16 bits
Commands	Read, set, activate
Bytes in the process image	– Only complex: 5 input and 5 output data bytes per channel + 1 status and 1 control byte per channel
Potential isolation	depending on bus system



Note

Field-wireable M23 connector (TURCK type code:
FW-M23ST12Q-G-LT-ME-XX-10, Ident-Nr: 6604070).

Wiring diagram

Figure 62:
Pin configuration

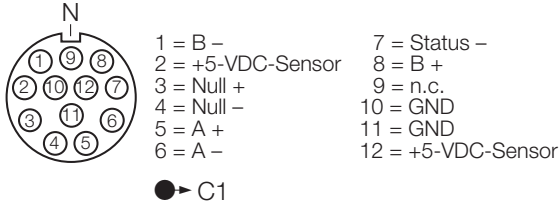

Gate/Latch input:

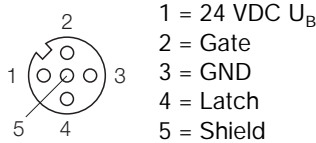

Functions of the channel LEDs

Table 129:
Channel LED
indications

LED	Status	Meaning
A, B, C	Green	Show the levels of channels A, B and C.
	OFF	Presently, there is no data transfer.
E	Red	If the encoder is equipped with an alarm or status output, this can be connected to pin 7 of the module. If this is low (0 VDC), the LED illuminates and bit 5 of the status byte is set.
	OFF	No error

Process data

Table 130:
Process data

Signals	Description
Inputs A, \bar{A}	Pulse input in the module's encoder or counter mode
Inputs B, \bar{B}	Phase-displaced pulse input in the module's counter mode
Inputs C, \bar{C}	Zero pulse input for the latch register of the module. This input is activated via the bit "EN_LATC" in the control byte of the module
External latch 24 V	Additional latch input of the module This input is activated via the bit "EN_LATC_EXT" in the control byte of the module. If this input is active and an edge shift of 0 to 24 V occurs, then the counter value is latched.
External gate 24 V	A high level at this contact suppresses the counter function.
Status input:	If the incremental encoder is equipped with an alarm output, then this can be connected to the status input (active low input with internal pull-up circuitry).
U_B	Voltage supply for electronics and encoder
U_L , GND	A voltage supply of 0 V and 24 V must be applied to these contacts for module operation.

Parameters

Detailed information on fieldbus-dependent parameterisation of the modules is contained in the chapter "Parameters of the *piconet*[®] I/O modules" of the following manuals:

- Profibus-DP
German: „*piconet*[®] for PROFIBUS-DP“, D300775
English: „*piconet*[®] for PROFIBUS-DP“, D300776
- DeviceNet
Not yet published
- CANopen
Not yet published

Diagnosis

Diagnostics via LEDs

Please read the description of the diagnostic LEDs in the event of local errors of the coupling and extension modules in Chapter 5 of this manual: Fieldbus-specific diagnostic indications via LEDs are described in the chapter "Error treatment and diagnostics" of the above mentioned manuals.

Diagnostics via software

Detailed information on fieldbus-dependent diagnostics of the modules is contained in the chapter "Error treatment and diagnostics" of the above mentioned manuals.

Data mapping



Note

Data mapping of the *piconet*[®] modules depends on the type of fieldbus.

For this, please refer to the mapping descriptions in chapter "Data mapping of the *piconet*[®] modules" of the respective bus-specific manuals.

Control and status byte

The control byte is contained in the output image and can be read or written.

The status byte is contained in the input image and can only be read.

Process data operation

The control and status byte are used in process data transfer to establish data transmission (handshake).

- Control byte

*Table 131:
Control byte
Incremental
encoder*

Bit	7	6	5	4	3	2	1	0
Name	RegAccess	-	-	-	-	CNT_SET	EN_LAT_EXT/ RD_PERIOD	EN_LATC

*Table 132:
Meaning of the
control byte bits*

Name	Description
RegAccess	0 = Register communication disabled, Process data operation
CNT_SET	With a rising edge of the bit "CNT_SET", the counter is set to the value determined by the process data in Reg0 and Reg1 (see "Mapping" in the bus-specific <i>piconet</i> [®] manual).

Name	Description
EN_LAT_EXT	The external latch input "Gate/Latch" (M12 input) is activated. Upon the first external latch pulse following a valid "EN_LAT_EXT" bit, the counter value is saved in the latch register. The following pulses have no influence on the latch register if the bit is set. Please ensure that the according "latch valid bit" (LAT_EXT_VAL) is reset prior to activating the zero pulse. This function can be adjusted in the feature register (default setting).
RD_PERIOD	The period between two positive edges of the input A is measured with a resolution of 250 ns. The period is output by data bytes D3 and D4 if the bit set. This function can be adjusted in the feature register.
EN_LATC	The zero latch input (C input, M23 input) is activated. Upon receipt of the first external latch pulse following a valid "EN_LATC" bit, the counter value is saved in the latch register (priority over EN_LAT-EXT). The following pulses have no influence on the latch register if the bit is set. Please ensure that the according "latch valid bit" (LAT_VAL) is reset prior to activating the zero pulse. (the latch valid bit can only be reset by the module, if the C pulse features a low level).

■ Status byte

Table 133:
Status byte
incremental
encoder module

Bit	7	6	5	4	3	2	1	0
Name	Reg Access	-	STATUS_INPUT	OVERFLOW	UNDERFLOW	CNTSET_ACC	LAT_EXT_VAL/RD_PERIOD_Q	LATC_VAL

Table 134:
Meaning of the
status byte bits

Name	Description
RegAccess	0 = Acknowledgement of process data operation (Control and status byte handshake)
STATUS_INPUT	Shows the status of the status input, i.e. of the connected encoder. It is activated via the feature register.
OVERFLOW	If an overflow of the 16-bit counter occurs (65535 → 0), then this bit is set. It is reset, if the counter exceeds the measuring range by a third (21845 → 21846) or as soon as an underflow occurs (see Figure 63:).
UNDERFLOW	If an underflow of the 16-bit counter occurs (0 → 65535), then this bit is set. It is reset, if the counter underflow is below two-thirds of the measuring range (43690 → 43689) or as soon as an overflow occurs (see Figure 63:).
CNTSET_ACC	Data to set the counter have been accepted by the module.
LAT_EXT_VAL	An external latch pulse applies to "Gate/Latch" (M12 input). Data D3, D4 in the process image accord to the actual counter value if the bit set. In order to re-activate the latch input, EN_LAT_EXT must first be reset and then set again.
RD_PERIOD_Q	Data bytes D3 and D4 comprise the period duration.
LATC_VAL	Zero latch at C input (M23). Data D3, D4 in the process image accord to the actual counter value if the bit set. In order to re-activate the latch input, EN_LATC must first be reset and then set again.

Figure 63:
Overflow/
Underflow

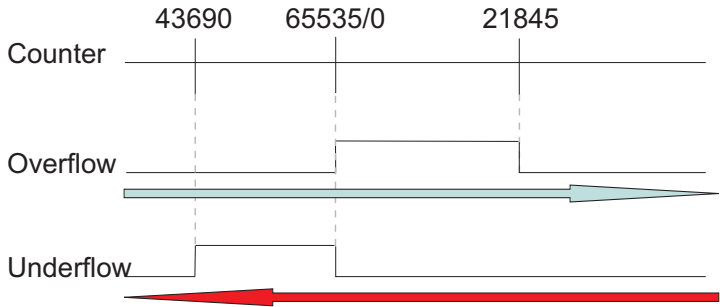

Register communication



Note

During register communication measuring values cannot be transferred.

- Control byte

Table 135:
Control byte
incremental
encoder module

Bit	7	6	5	4	3	2	1	0
Name	RegAccess	R/W	Register number					

Table 136:
Meaning of the
control byte bits

Name	Description
RegAccess	1 = Register communication enabled, no process data operation
R/W	0 = Read: Registers can be read 1 = Write: Registers can be written
Register number	Number of the register that is to be read or written.

- Status byte

Table 137:
Status byte
incremental
encoder module

Bit	7	6	5	4	3	2	1	0
Name	RegAccess	R/W	Register number					

Table 138:
Meaning of the
status byte bits

Name	Description
RegAccess	1 = Acknowledgement for register access
R/W	0 = Read: Register has been read
Register number	Number of the register that has been read or written.

Register overview

Table 139:
Register overview

Register	Designation	Default value (in hex)	R/W	Memory
R0 up to R 7	reserved	0000	R	
R8	Module type	13F5	R	ROM
R9	Software version	XXXX	R	ROM
R10	Multiplex shift register	0218/ 0130	R	ROM
R11	Signal channels	0130	R	ROM
R12	Minimum data length	3030	R	ROM
R13	Data structure	0000	R	ROM
R14	reserved	0000	R	
R15	Alignment register	Variable	R/W	RAM
R16	Hardware version number	XXXX	R/W	SEEROM
R17 to R30	reserved	0000	R	
R31	Code word register	Variable	R/W	RAM
R32	Feature register	0000	R/W	SEEROM
R33 to R47	reserved	0000	R	

Data byte D2



Note

During period measurement data byte D2 is not used.

Table 140:
Data byte D2

Bit	7	6	5	4	3	2	1	0
Name	-	-	INPUT_A	INPUT_B	INPUT_C	INPUT_ERR	LATCH	Gate

Table 141:
Description

Name	Description
INPUT_A	Status of input channel A
INPUT_B	Status of input channel B
INPUT_C	Status of input channel C
INPUT_ERR	Status of alarm channel
LATCH	Status of LATCH input at M12 connector
GATE	Status of GATE input at M12 connector

Feature register (R32)

The feature register determines the operating mode of the module.

Table 142:
Feature register
incremental
encoder module

A Default
setting

Bit	Value	Description
0	-	reserved
1		Disabling the counter
	0	The counter is inhibited with a high level at the gate input A
	1	The counter is inhibited with a low level at the gate input
3, 2		Status input
	00	Status input (active low) is shown in the status byte, bit 5 A Status byte, bit 5 = Status input
	01	reserved
	10	Status input (active high) is shown in status byte, bit 5 and in status byte, bit 6. Status byte, bit 5 = Status input, Status byte, bit 6 = Status input
	11	Status input (active high) is shown in status byte, bit 5 and inverted in status byte, bit 6. Status byte, bit 5 = Status input, Status byte, bit 6 = !Status input
4	0	External latch function active A
	1	Period duration measurement active
6, 5		reserved
9 to 7		reserved

Bit	Value (bin)	Description
11,10		Encoder signal evaluation
	00	4-fold evaluation of the encoder signals A, B and C, i.e. both rising and falling edges of the encoder signals A and B are counted A
	01	1-fold evaluation of the encoder signals A, B and C, i.e. each period of the encoder signal A is counted.
	10	2-fold evaluation of the encoder signals A, B and C, i.e. each edge of the encoder signal A is counted.
	11	4-fold evaluation of the encoder signals A, B and C
14 to 12		reserved
15		Counter function
	0	Encoder interface A
	1	Counter mode is activated. 16-bit up/down counter – Input A: Counter – Input B: Counting direction (5 V or open = up, 0 V = down) – Input C: Latch

Sxxx-10S-x002, 1-channel RS232 interface

The interface module Sxxx-10S-x002 is designed for connection of devices with an RS232 interface. The interface complies with CCITT V.28/DIN 66 259-1 standards.

The module provides fully transparent data transfer to the higher level automation device via a status and control byte handshake between module and controller. This does not affect the protocol of the serial interface. The active serial communication channel operates independently of the higher level bus system in full duplex mode with up to 19,200 bit/s, with a 128-byte input and a 16-byte send buffer.

The RS232 interface guarantees high interference immunity due to galvanically isolated signal transfer.

The module is either parameterised via the fieldbus or the additional configuration tool "I/O-ASSISTANT" via the configuration interface. Parameters are stored permanently in the module, even in the event of a power failure.

Figure 64:
SDPB-10S-x002,
SNNE-10S-x002

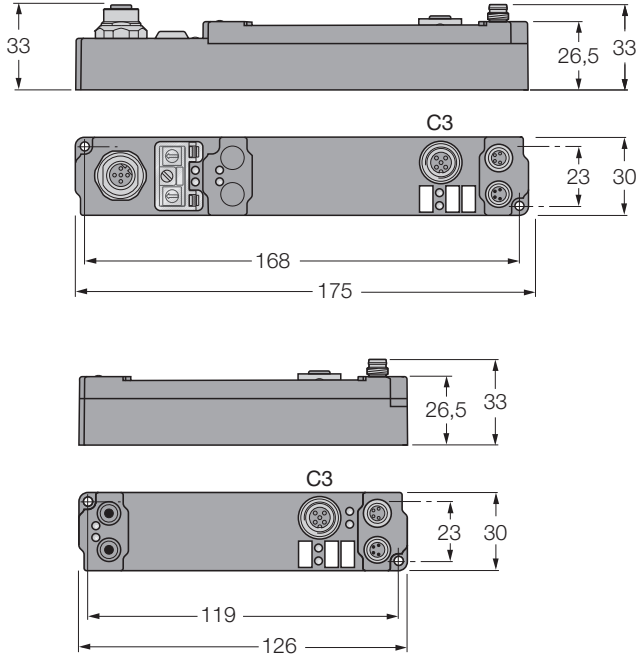

Technical data

Table 143:
Technical data
SxxB-10S-x005

Designation	SxxB-10S-x002
Number of channels	1TxD and 1RxD, full duplex
Transmission rate	1200 to 19200 baud, 9600 baud (8 data bits, no parity, one stop bit)
Connection RS232	Female 5-pole M12 connector Threaded connector
Bit distortion	< 3 %
RS232 line length	Max. 15 m
Signal voltage LOW	3 V to 18 V
Signal voltage HIGH	-18 V to -3 V
Data buffer	– Receive buffer: 128 bytes – Send buffer: 16 bytes
Bytes in the process image	– Only complex: 5 input and 5 output data bytes per channel + 1 status and 1 control byte per channel
Potential isolation	RS232/Operating voltage: 500 V _{eff} Operating voltage/fieldbus: depending on bus system
Operating temperature	0°C to +55°C
Storage temperature	-25°C to +85°C
Vibration proofness	according to IEC 68, part 2-6 / IEC 68, part 2-27
EMC	to EN 50082-2 /EN 50081-2
Degree of protection	IP65/66/67 (to EN 60529)
Mounting position	any

Wiring diagram

Figure 65:
Pin configuration

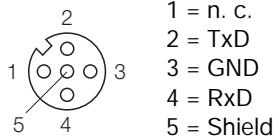

Functions of the channel LEDs

Table 144:
Channel LED
indications

LED	Status	Meaning
R "Run"	Green	Active data transfer
	OFF	Presently, there is no data transfer.
E „Error“	red	Data transmission error
	OFF	Error-free data transfer

Parameters

Detailed information on fieldbus-dependent parameterisation of the modules is contained in the chapter "Parameters of the *piconet*[®] I/O modules" of the following manuals:

- Profibus-DP
German: „*piconet*[®] for PROFIBUS-DP“, D300775
English: „*piconet*[®] for PROFIBUS-DP“, D300776
- DeviceNet
Not yet published
- CANopen
Not yet published

Diagnosis

Diagnostics via LEDs

Please read the description of the diagnostic LEDs in the event of local errors of the coupling and extension modules in Chapter 5 of this manual: Fieldbus-specific diagnostic indications via LEDs are described in the chapter "Error treatment and diagnostics" of the above mentioned manuals.

Diagnostics via software

Detailed information on fieldbus-dependent diagnostics of the modules is contained in the chapter "Error treatment and diagnostics" of the above mentioned manuals.

Data mapping



Note

Data mapping of the *piconet*[®] modules depends on the type of fieldbus.

For this, please refer to the mapping descriptions in chapter "Data mapping of the *piconet*[®] modules" of the respective bus-specific manuals.

Control and status byte

The control and status byte are only visible, if the module is operated in the complex mode.

The control byte is contained in the output image and can be read or written.

The status byte is contained in the input image and can only be read.

Process data operation

The control and status byte are used in process data transfer to establish data transmission (handshake).

■ Control byte

Table 145:
Control byte
RS232 module

Bit	7	6	5	4	3	2	1	0
Name	RegAccess	OL2	OL1	OL0	-	IR	RA	TR

Table 146:
Meaning of the
control byte bits

Name	Description
RegAccess	0 = Register communication disabled, Process data operation
OL2-OL0	Number of data bytes sent
IR	Handshake bit for module initialisation. If bit "IR" = 1, then the module is initialised. Send and receive functions are inhibited, the FIFO counters are reset and the interface is initialised with the module register values (R32-R35, R18). Initialisation is acknowledged with the bit "IA".
RA	Acknowledgement of acceptance of data from IL0-IL2 in D0-D4. New data will only be transferred from the module to the controller after acknowledgement.
TR	Handshake bit for data transmission. A status change of "TR" initiates transfer of data to the send FIFO. The data volume is determined by OL0-OL2 (max. 5 bytes). The module signals execution of this command via "TA".

■ Status byte

Table 147:
Status byte
RS232 module

Bit	7	6	5	4	3	2	1	0
Name	Reg Access	IL2	IL1	ILO	BUF_F	IA	RR	TA

Table 148:
Meaning of the
status byte bits

Name	Description
RegAccess	0 = Acknowledgement of process data operation (control and status byte handshake)
IL2 - ILO	Number of data bytes received
BUF_F	Receive buffer full, further data will be lost
IA	Handshake bit for module initialisation. Module initialisation acknowledgement
RR	Handshake bit for data receipt. The controller is informed via a status change of "RR" that the number of data indicated by ILO-IL2 are contained in D0-D4. Data acceptance is acknowledged by the control byte with RA; new data will only be transferred to the controller after acknowledgement.
TA	Handshake bit for data transmission. A "TR" in the control byte confirms execution of the send command.



Note

Upon initial receipt of data there is only 1 byte in the buffer because the module does not know whether further data will follow.

Examples

- Receipt of data

*Table 149:
Receipt of data*

Output Control Byte	Input Status Byte	Description
0000_0000	0xxx_x00x	Start of data transfer
0xxx_000x	0011_x01x	3 bytes in data bytes 0 to 4 are ready for transfer.
0xxx_001x	0011_x01x	Acknowledgement that data have been transferred
0xxx_001x	0101_x00x	5 bytes in data bytes 0 to 4 are ready for transfer.
0xxx_000x	0101_x00x	Acknowledgement that data have been transferred

- Transfer of data

*Table 150:
Transfer of data*

Output Control Byte	Input Status Byte	Description
0000_0000	0xxx_x0x0	Start of data transfer
0010_00x1	0xxx_x0x0	2 bytes of the data bytes are to be sent
0010_00x1	0xxx_x0x1	2 bytes data loaded to the send FIFO → data are being sent
0101_00x0	0xxx_x0x1	5 bytes of the data bytes are to be sent
0101_00x0	0xxx_x0x0	5 bytes data loaded to the send FIFO, data are being sent

■ Module initialisation

Table 151:
Module
initialisation

Output Control Byte	Input Status Byte	Description
0xxx_xxxx	0xxx_xxxx	Start of data transfer
0000_0100	0xxx_xxxx	Module is to be initialised
0000_0100	0000_0100	Module has completed initialisation
0000_0000	0000_0100	Restore module data exchange mode
0000_0000	0000_0000	Module is operational



Attention

If a parity, framing or over-run error occurs, then the related transmission data are lost and thus not transferred to the "Receive FIFO" of the module.

If the buffer is full, then further incoming data will be ignored.

In the event of an error, the according diagnostic bits in register 6 are set.

Register communication



Note

During register communication serial data cannot be transferred.

- Control byte

Table 152:
Control byte
RS232 module

Bit	7	6	5	4	3	2	1	0
Name	RegAccess	R/W						Register number

Table 153:
Meaning of the
control byte bits

Name	Description
RegAccess	1 = Register communication enabled, no process data operation
R/W	0 = Read: Registers can be read 1 = Write: Registers can be written
Register number	Number of the register that is to be read or written.

- Status byte

Table 154:
Status byte
RS485 module

Bit	7	6	5	4	3	2	1	0
Name	RegAccess	R/W						Register number

Table 155:
Meaning of the
status byte bits

Name	Description
RegAccess	1 = Acknowledgement for register access
R/W	0 = Read: Register has been read
Register number	Number of the register that has been read or written.

Register overview

Table 156:
Register overview

Register	Designation	Default value (in hex)	R/W	Memory
R0	Number of data bytes in the send buffer	Variable	R	RAM
R1	Number of data bytes in the receive buffer	Variable	R	RAM
R2 up to R 5	reserved	0000h		
R6	Diagnostic register	Variable	R	RAM
R7	reserved	0000		
R8	Module type	1772	R	ROM
R9	Software version	XXXX	R	ROM
R10	Multiplex shift register	0218	R	ROM
R11	Signal channels	0230	R	ROM
R12	Minimum data length	5050	R	ROM
R13	Data structure	0000	R	ROM
R14	reserved	0000	R	
R15	Alignment register	Variable	R/W	RAM
R16	Hardware version number	XXXX	R/W	SEEROM
R17	reserved	0000	R/W	
R18	Buffer capacity	0080	R/W	SEEROM
R19 to R30	reserved	0000	R/W	
R31	Code word register	Variable	R/W	RAM

R32	Baud rate register	0006	R/W	SEEROM
R33	Data frame register	0003	R/W	SEEROM
R34	Feature register	0000	R/W	SEEROM
R35	Diagnostic byte register	0005	R/W	SEEROM
R36 to R47	reserved	0000	R	

Diagnostic register (R6)

Table 157:
Diagnostic register

Bit no.	Value	Meaning
0	1	Receive buffer overflow, further data are lost
1	1	A parity error has occurred
2	1	A framing error has occurred
3	1	An overrun has occurred
4	1	Buffer is full
5-15	-	reserved



Attention

If a parity, framing or over-run error occurs, then the related transmission data are lost and thus not transferred to the "Receive FIFO" of the module.

If the buffer is full, then further incoming data will be ignored.

In the event of an error, the according diagnostic bits in register 6 are set.

Buffer size (R18)

The register R18 defines the number of data in the receive FIFO from which on the bit register communication "BUF_F" in the status byte is set.

- Low Byte: if this value is reached, then BUF_F in set in the status byte
- High Byte: reserved

Baud rate register (R32)

The required data transmission rate can be set in the baud rate register.

Table 158:
Baud rate register
of the RS232
module

A Default
setting

Bit	Value	Description
0-3	0011	1200 Baud
	0100	2400 Baud
	0101	4800 Baud
	0110	9600 Baud A
	0111	19200 Baud
	1000	38400 Baud (in preparation)
	1001	56600 Baud (in preparation)
	1010	115000 Baud (in preparation)
4 to 15	reserved	

Data frame register (R33)

The required transmission frame can be set in the data frame register.

Table 159:
Data frame
register of the
RS232 module

	Bit	Value	Data frame
A Default setting	0-2	001	7 data bits, even parity
		010	7 data bits, odd parity
		011	8 data bits, no parity A
		100	8 data bits, even parity
		101	8 data bits, odd parity
3	0	1 stop bit A	
	1	2 stop bits	
	4 to 15	reserved	

Feature register (R34)

The feature register determines the operating mode of the module.

Table 160:
Feature register
RS232 module

A Default
setting

Bit	Value	Description
0	-	reserved
1	-	reserved
2		Status one cycle later
	0	Inactive
	1	Active A The status byte is copied to the IP-Link shift registers by the module a cycle later than the most significant data bytes. As a result the data transmission rate to the controller is reduced.
3		XON/ XOFF send
	0	Inactive
	1	Active A The module supports the XON//XOFF protocol during data transfer, i.e. the module transmits the data sent by the controller, until it receives the character XOFF (DC3== 0x13) from its partner. Data transfer is then inhibited until the character XON (DC1==0x11) is received.
4		XON/ XOFF receive
	0	Inactive
	1	Active A The XON/XOFF protocol is supported by the module during data transfer. The module sends the control character XOFF, if 118 characters are in the buffer of the module; XON is sent, if XOFF has been sent previously and the buffer limit of 18 bytes has been under-ranged.
5	-	reserved

Bit	Value	Description
6		Send 16 bytes
	0	Inactive
	1	Active A Continuous sending of data from the FIFO. The send buffer is filled by the controller (up to 16 bytes). With a rising edge of the control byte, bit 3, the full buffer contents is sent. Data transfer is acknowledged to the controller via the module by setting bit 2 of the status byte. Status byte, bit 2 is reset by the control byte, bit 3.
7 to 15	1	reserved

Data byte register (R35)

Determines the number of data bytes transferred between controller and module.

Table 161:
Data byte register
of the RS232
module

Bit	Value	Description
	(In hex)	
0	1h	1 bytes
to 7	2h	2 bytes
	3h	3 bytes
	4h	4 bytes
	5h	5 bytes
8 to 15	-	reserved

**Sxxx-10S-x004,
1-channel RS485/422 interface**

The interface module Sxxx-10S-x004 is designed for connection of devices with an RS422 or RS485 interface. The module provides fully transparent data transfer to the higher level automation device; data transfer via the fieldbus is established via a simple handshake protocol. This does not affect the protocol of the serial interface. The active serial communication channel operates independently of the higher level bus system in full duplex mode with up to 19.200 baud with a 128-byte receive and a 16-byte send buffer.

Differential signal transfer acc. to RS422 provides high interference immunity based on galvanic signal isolation.

The module is either parameterised via the fieldbus or the additional configuration tool "I/O-ASSISTANT" via the configuration interface.

Parameters are stored permanently in the module, even in the event of a power failure.

Figure 66:
SDPB-10S-x004,
SNNE-10S-x004

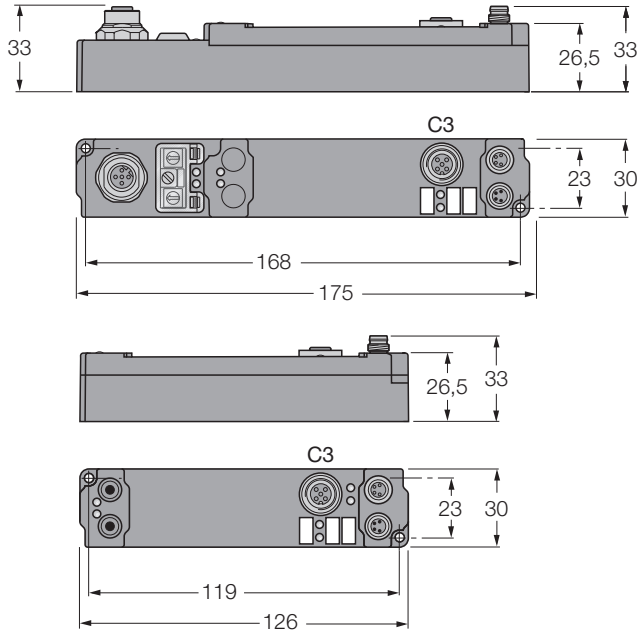

Technical data

Table 162:
Technical data
SxxB-10S-x004

Designation	SxxB-10S-x004
Voltage supply	
Operating voltage U_B	24 VDC (-15 %/+20 %)
Load voltage U_L	24 VDC (-15 %/+20 %)
Number of channels	1RS422 (full duplex), RS 485 (half duplex)
Transmission rate	1200 to 19200 baud, 9600 baud (8 data bits, no parity, one stop bit)
Connection RS232	Female 5-pole M12 connector Threaded connector
Bit transmission	with differential signal
Line impedance	120 Ohm
422/485 line length	max. 500 m twisted pair
Data buffer	- Receive buffer: 128 bytes - Send buffer: 16 bytes
Common mode voltage	-7 V to 12 V against ground
Bytes in the process image	- Only complex: 5 input and 5 output data bytes per channel + 1 status and 1 control byte per channel
Potential isolation	- RS422/485 operating voltage: 500 V _{eff} - Operating voltage/fieldbus: depending on bus system

Wiring diagram

Figure 67:
Pin configuration

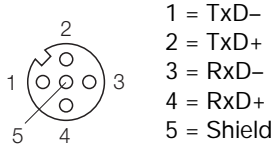
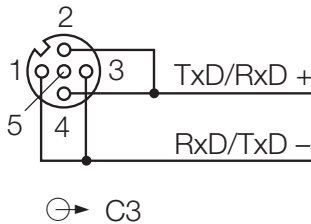

Figure 68:
Connection
example RS485
transmission



Functions of the channel LEDs

Table 163:
Channel LED
indications

LED	Status	Meaning
R "Run"	Green	Active data transfer
	OFF	Presently, there is no data transfer.
E „Error“	red	Data transmission error
	OFF	Error-free data transfer

Parameters

Detailed information on fieldbus-dependent parameterisation of the modules is contained in the chapter "Parameters of the *piconet*[®] I/O modules" of the following manuals:

- Profibus-DP
German: „*piconet*[®] for PROFIBUS-DP“, D300775
English: „*piconet*[®] for PROFIBUS-DP“, D300776
- DeviceNet
Not yet published
- CANopen
Not yet published

Diagnosis

Diagnostics via LEDs

Please read the description of the diagnostic LEDs in the event of local errors of the coupling and extension modules in Chapter 5 of this manual: Fieldbus-specific diagnostic indications via LEDs are described in the chapter "Error treatment and diagnostics" of the above mentioned manuals.

Diagnostics via software

Detailed information on fieldbus-dependent diagnostics of the modules is contained in the chapter "Error treatment and diagnostics" of the above mentioned manuals.

Data mapping



Note

Data mapping of the *piconet*[®] modules depends on the type of fieldbus.

For this, please refer to the mapping descriptions in chapter "Data mapping of the *piconet*[®] modules" of the respective bus-specific manuals.

Control and status byte



Note

Configuration of the control and status byte of the module Sxxx-10S-x004 is identical to that of RS232 module Sxxx-10S-x002, see page 12-24.

Register overview



Note

The register overview of the module Sxxx-10S-x004 accords to that of the RS232 module Sxxx-10S-x002, see page 12-30

Feature register (R34)

The feature register determines the operating mode of the module.

Table 164:
Feature register
RS485/422
module

A Default
setting

Bit	Value	Description
0		Half duplex A
	0	Active: Receipt of transferred data is suppressed.
	1	Inactive: "Listening" to the data sent in the RS485 mode.
1	-	reserved
2		Status one cycle later
	0	Inactive
	1	Active A The status byte is copied to the IP-Link shift registers by the module a cycle later than the most significant data bytes. As a result the data transmission rate to the controller is reduced.
3		XON/ XOFF send
	0	Inactive
	1	Active A The module supports the XON//XOFF protocol during data transfer, i.e. the module transmits the data sent by the controller, until it receives the character XOFF (DC3== 0x13) from its partner. Data transfer is then inhibited until the character XON (DC1==0x11) is received.

Bit	Value	Description
4	XON/ XOFF receive	
	0	Inactive
	1	Active A The XON/XOFF protocol is supported by the module during data transfer. The module sends the control character XOFF, if 118 characters are in the buffer of the module; XON is sent, if XOFF has been sent previously and the buffer limit of 18 bytes has been under-ranged.
5	Interface mode	
	0	According to the RS485 standard, the module is used within a bus structure. A
	1	The module is used as a point-to-point connection (RS422). It does not switch the data line with a high resistance.
6	Send 16 bytes	
	0	Inactive
	1	Active A Continuous sending of data from the FIFO. The send buffer is filled by the controller (up to 16 bytes). With a rising edge of the control byte, bit 3, the full buffer contents is sent. Data transfer is acknowledged to the controller via the module by setting bit 2 of the status byte. Status byte, bit 2 is reset by the control byte, bit 3.
7 to 15	1	reserved

**Note**

The registers R6 (diagnostic register), R18 (buffer capacity), R32 (baud rate register) and R33 (data frame register) of the module Sxxx-10S-x004 accord to those of the RS232 module Sxxx-10S-x002, see page 12-31 see page 12-33.

Sxxx-10S-x005, 1-channel SSI interface

The SSI module Sxxx-10S-x005 is designed for direct connection of an SSI encoder to the *piconet*[®] system. The encoder is powered via the SSI interface.

The interface circuitry issues a cyclic signal for read-out of the encoder and provides the incoming data flow as a data word in the process image to the controller. The module outputs data as dual numbers or binary numbers (gray code). The direction of rotation is configurable. The baud rate is set to 250 kHz. Process data are output in the input data bytes D0 - D3.

Various operating modes, transmission frequencies and bit lengths can be permanently adjusted via the control registers. The individual configuration is stored permanently in a register set.

The module is either parameterised via the fieldbus or the additional configuration tool "I/O-ASSISTANT" via the configuration interface. Parameters are stored permanently in the module, even in the event of a power failure.

Figure 69:
SDPB-10S-x005,
SNNE-10S--x005

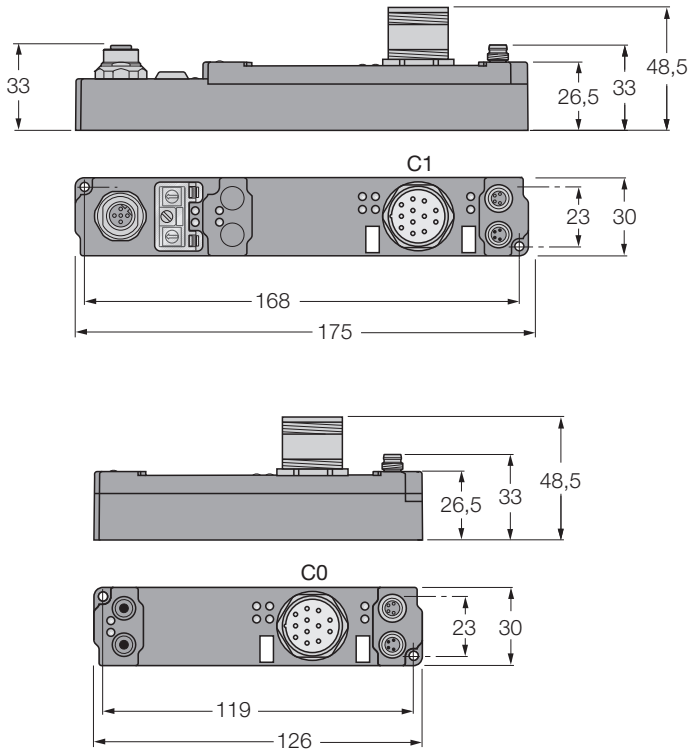

Technical data

Table 165:
Technical data
Sxxx-10S-x005

Designation	Sxxx-10S-x005
Voltage supply	
Operating voltage U_B	24 VDC (-15 %/+20 %)
Load voltage U_L	24 VDC (-15 %/+20 %)
Number of channels	1
Encoder connection	M23 threaded connectors, 12-pole with external thread
Signal type	Differential signal (RS485)
Encoder supply	24 VDC, from load voltage
Transmission rate	adjustable up to 1 MHz, preset to 250 kHz
serial input	24 bits (adjustable)
Data direction	Read
Bytes in the process image	<ul style="list-style-type: none"> - Compact: 4 input data bytes per channel - Complex: 5 input and 5 output data bytes per channel + 1 status and 1 control byte per channel
Potential isolation	depending on bus system



Note

Field-wireable M23 connector (TURCK type code:
FW-M23ST12Q-G-LT-ME-XX-10, Ident-Nr: 6604070).

Wiring diagram

Figure 70:
Pin configuration
of the M23
connector of the
piconet® module

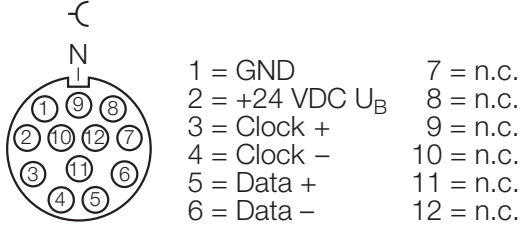

Functions of the channel LEDs

Table 166:
Channel LED
indications

LED	Status	Meaning
R "Run"	Green	Active data transfer
	OFF	Presently, there is no data transfer.

Process data

Table 167:
Process data

Signals	Description
Outputs clock+ / clock-	Pulse output for the SSI encoder
Inputs data+ / data-	Differential signal inputs (RS485)
24 VDC U_B	Voltage output for encoder supply
U_B	Voltage supply for electronics and encoder
U_L , GND	A voltage supply of 0 V and 24 V must be applied to these contacts for module operation.

Parameters

Detailed information on fieldbus-dependent parameterisation of the modules is contained in the chapter "Parameters of the *piconet*[®] I/O modules" of the following manuals:

- Profibus-DP
German: „*piconet*[®] for PROFIBUS-DP“, D300775
English: „*piconet*[®] for PROFIBUS-DP“, D300776
- DeviceNet
Not yet published
- CANopen
Not yet published

Diagnosis

Diagnostics via LEDs

Please read the description of the diagnostic LEDs in the event of local errors of the coupling and extension modules in Chapter 5 of this manual: Fieldbus-specific diagnostic indications via LEDs are described in the chapter "Error treatment and diagnostics" of the above mentioned manuals.

Diagnostics via software

Detailed information on fieldbus-dependent diagnostics of the modules is contained in the chapter "Error treatment and diagnostics" of the above mentioned manuals.

Data mapping



Note

Data mapping of the *piconet*[®] modules depends on the type of fieldbus.

For this, please refer to the mapping descriptions in chapter "Data mapping of the *piconet*[®] modules" of the respective bus-specific manuals.

Control and status byte

The control and status byte are only visible, if the module is operated in the complex mode.

The control byte is contained in the output image and can be read or written.

The status byte is contained in the input image and can only be read.

Process data operation

■ Control byte

<i>Table 168: Control byte SSI module</i>		Bit	7	6	5	4	3	2	1	0
		Name	RegAccess					reserved		

<i>Table 169: Meaning of the control byte bits</i>		Name	Description
		RegAccess	0 = Register communication disabled, process data operation

■ Status byte

<i>Table 170: Status byte SSI module</i>		Bit	7	6	5	4	3	2	1	0
		Name	RegAccess	Error	0	0	0	0	FRAME_E	SSL_IN_E

Table 171:
Meaning of the
status byte bits

Name	Description
RegAccess	0 = Acknowledgement of process data operation
Error	A general occur has occurred. This bit is set, if an error has occurred in bit FRAME_E or SSI_IN_E.
FRAME_E	There is a faulty data frame, i.e. the data frame is not terminated with zero. – Possible causes: Wire-break on clock lines
SSI_IN_E	The SSI input of the terminal is at low level, if there is no data transfer. – Possible causes: SSI without power supply, or wire-break at SSI data inputs "D+" or "D-" or data lines interchanged.

Register communication

- Control byte

Table 172:
Control byte
SSI module

Bit	7	6	5	4	3	2	1	0
Name	RegAccess	R/W						Register number

Table 173:
Meaning of the
control byte bits

Name	Description
RegAccess	1 = Register communication enabled, no process data operation
R/W	0 = Read: Registers can be read 1 = Write: Registers can be written
Register number	Number of the register that is to be read or written.

■ Status byte

Table 174:
Status byte
SSI module

Bit	7	6	5	4	3	2	1	0
Name	RegAccess	R/W						Register number

Table 175:
Meaning of the
status byte bits

Name	Description
RegAccess	1 = Acknowledgement for register access
R/W	0 = Read: Register has been read
Register number	Number of the register that has been read or written.

Register overview

Table 176:
Register overview

Register	Designation	Default R/W		Memory
		value		
R0	reserved	0000	R	
...	...			
R8	Module type	1391	R	ROM
R9	Software version	XXXX	R	ROM
R10	Multiplex shift register	0218/ 0130	R	ROM
R11	Signal channels	0128	R	ROM
R12	Minimum data length	00A8	R	ROM
R13	Data structure	0000	R	ROM
R14	reserved	0000	R	
R15	Alignment register	Variable	R/W	RAM
R16	Hardware version number	XXXX	R/W	SEEROM
R17	reserved	0000hex	R	
...
R30	reserved	0000hex	R	
R31	Code word register	Variable	R/W	RAM
R32	Feature register	0001	R/W	SEEROM
R33	Baud rate	0002	R	
R34	Data length	0018	R	
R35	reserved	0000	R	
...

Feature register (R32)

The basic settings of the module can be modified in the feature register.

Default settings: 0x0001

Table 177:
Feature register
SSI module

A Default
setting

Bit	Value	Description
0	0	Binary output → Binary value output.
	1	Gray code A → Gray code value output.
1	0	reserved
2	0	Asynchronous A
	1	Synchronous mode The data are loaded synchronously to the read cycle of the internal bus.
3	0	Multiturn evaluation of the encoder A
	1	Single-turn evaluation of the encoder
4	0	Disable Frame Error A After the last valid bit there is no verification whether the data line provides a zero signal.
	1	Enable Frame Error After the last valid bit it is verified whether the data line provides a zero signal.

Baud rate register (R33)

In the baud rate register, the baud rate for reading the SSI data is set.

Default settings: 0x0002

<i>Table 178: Baud rate register of the SSI module</i>	Value	Description
A <i>Default setting</i>	0x0000	reserved
	0x0001	1 MHz
	0x0002	250 kHz A
	0x0003	125 kHz
	0x0004	100 kHz
	0x0005	83 kHz
	0x0006	71 kHz
	0x0007	62,5 kHz
	0x0008	reserved
	...	
	0xFFFF	reserved

Data length register (R34)

In the data length register the data length, which is displayed in the process image is set.

Default settings: 0x0018 (24 bits data length)

<i>Table 179: Data length register of the SSI module</i>	Bit	Value (in hex)	Description
A <i>Default setting</i>	0 to 7	0h	0 bit data length
		1h	1 bit data length
		...	
		18h	24 bits data length A
		...	
		20h	32 bit data length
		21h to FFh	reserved
	8 to 15	reserved	

**Sxxx-0002D-x002,
2-channel pulse width output 24 VDC/2.5 A**

The outputs of the module Sxxx-0002D-x002D are used to modulate the pulse width of the binary signal. Modulation implies that either the frequency or the pulse width/pulse length is influenced and continuously output. It is also possible to output a defined number of pulses (Cnt_Cnt_PWM Modus).

The basic frequency and the pulse pause ratio can be adjusted via 16-bit values in the process image of the controller.

The module uses 6 bytes in the process image (ex factory setting). The mapping can be adjusted via the control system or the configuration software "I/O-ASSISTANT".

Alongside the operating mode PWM (pulse width modulation), the module can also be operated in the modes FM (frequency modulation or step motor control with preset pulse direction (Frq-Cnt-Pulse-Mode). Per default the module is set to the PWM mode with a fundamental frequency of 250 Hz and a resolution of 10 bits.

The field connection level of the module electronics features galvanic isolation from the fieldbus, resp. the IP-Link.

The module is either parameterised via the fieldbus or the additional configuration tool "I/O-ASSISTANT" via the configuration interface. Parameters are stored permanently in the module, even in the event of a power failure.



Note

The module is temperature-monitored. In case of a temperature overrange, the outputs are switched off, the red Error LED at the output illuminates and an error bit in the status byte is set.

Figure 71:
SDPB-0002D-x002,
SNNE-0002D-x002

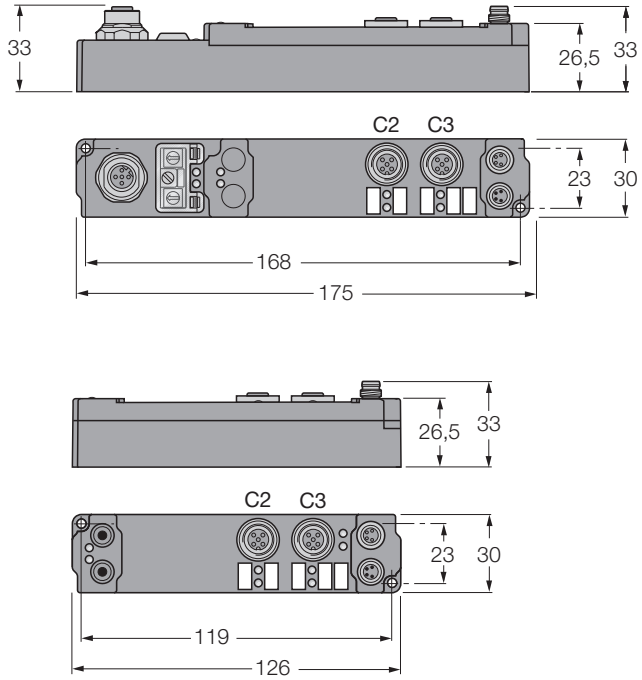

Technical data

Table 180: Technical data Sxxx-0002D-x002	Designation	Sxxx-0002D-x002,
	Voltage supply	
	Operating voltage U_B	24 VDC (-15 %/+20 %)
	Load voltage U_L	24 VDC (-15 %/+20 %)
	Number of outputs	2
	Signal connection	M12 threaded connectors
	Load type	ohmic, inductive
	Nominal load voltage	24 VDC (-15 %/+20 %)
	Output current	– Sxxx-0002D-x002: max. 2.5 A per channel, individually short-circuit protected
	Fundamental frequency	2 Hz to 20 kHz, default: 250 Hz
	Cycle rate	0 % to 100 % ($T_{on} > 750$ ns, $T_{off} > 500$ ns)
	Resolution	Max. 10 bits
	Free-wheeling diode (output)	yes
	Bytes in the process image	– Only complex: 2 input and 2 output data bytes per channel + 1 status and 1 control byte per channel
Potential isolation	– Channels/Operating voltage: no – Between the channels: no – Operating voltage/fieldbus: yes	

Wiring diagram

Figure 72:
Pin configuration

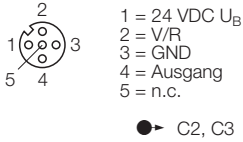

Functions of the channel LEDs

Table 181:
Channel LED
indications

LED	Status	Meaning
R "Run"	Green	Active data transfer
	OFF	Presently, there is no data transfer.
E „Error“	red	Data transmission error
	OFF	Error-free data transfer



Note

The modules have two channels whose signal status is signalled via LEDs. The LEDs are pulsed with the outputs and indicate the cycle rate via their brightness.

Operating modes

The various operating modes of the module are set in the feature register (R32). Three parameters are adjustable:

- Pulse width ratio
- Pulse length
- Frequency (period duration)

These parameters may correlate, depending on the operating mode!



Attention

The frequency limit values are not monitored. If different frequencies are adjusted in the various operating modes, device errors may occur.



Attention

If the pulse motor function (Frq_Cnt_PWM, Frq_Cnt_Impuls, Cnt_Cnt_PWM) has been selected, only channel 1 can be used.

PWM Mode

The frequency is entered via the register, whereas the pulse width is set via the process data.

In the PWMH and PWML mode two channels can be used. **In this case the operating mode and the period settings apply to both channels.**

The ratio between "Duty cycle" and period duration is determined via the process data (100 % ON period with the process data 0x7FFF). The "Duty cycle" defines the ratio between the ON and OFF status.

Via the register R2 you can set the the period duration, i.e. the frequency, during operation. After system start-up, this register is automatically loaded from the register R35 (SEEPROM). The application default setting should thus be stored in the R35 register.

Figure 73:
Examples

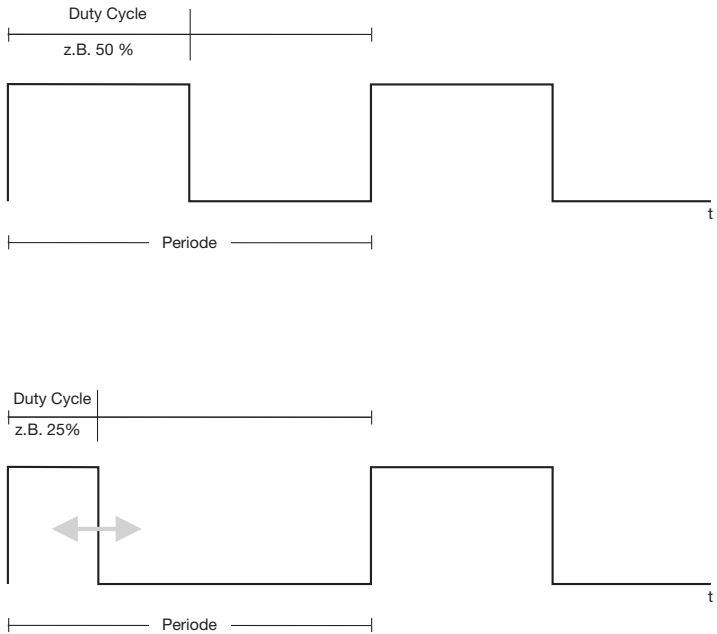

PWMH Mode

Frequency range: 1 kHz to 80 kHz

(Default setting: 0xFA0 in R2 accords to 1 kHz).

The period duration (frequency) is defined in register R2 (R35).

Table 182:
PWMH Mode

Parameters	Memory location
Period duration	R2 (R35)
Duty cycle	Process data

Period duration: 1 digit = 0.25 μ s.

The duty cycle is set via the process data.

$$0x7FFF_{\text{hex}} = 100 \%$$

$$0x1FFF_{\text{hex}} = 25 \%$$

Calculation example:

Calculation of the period duration in Hex:

1 Conversion frequency/period duration: (1Hz = 1/s):

$$\begin{aligned}
 1000\text{Hz} &= 1/100 \text{ Hz} \\
 &= 0.001 \text{ s} \\
 &= 1 \text{ ms} \\
 &= \underline{\underline{1000 \mu\text{s}}}
 \end{aligned}$$

$$\begin{aligned}
 2 \text{ Digit [dec]} &= \text{Period duration } [\mu\text{s}] \\
 &\quad / \text{Conversion factor [here } 0.25 \mu\text{s}] \\
 \text{Digit} &= 1000 \mu\text{s} / 0,25 \mu\text{s} \\
 &= 4000_{\text{dec}} \\
 &= \underline{\underline{0FA0}}_{\text{hex}}
 \end{aligned}$$

=> This value is now entered in R35.

<i>Table 183: Conversion Period duration/ Hex value</i>	Frequency	Period duration	dec.	hex
	1 kHz	1000 μs	4000 _{dec}	0FA0 _{hex}
	2 kHz	500 μs	2000 _{dec}	07D0 _{hex}
	5 kHz	200 μs	800 _{dec}	0320 _{hex}
	10 kHz	100 μs	400 _{dec}	0190 _{hex}
	20 kHz	50 μs	200 _{dec}	00C8 _{hex}

PWML Mode

Frequency range: 8 Hz to 1 kHz.

The period duration (frequency) is defined in register R2 (R35).

Table 184:
PWML Mode

Parameters	Memory location
Period duration	R2 (R35)
Duty cycle	Process data

Period duration: 1 digit = 2 μ sec.

The duty cycle is set via the process data:

$$0x7FFF_{\text{hex}} = 100 \%$$

$$0x1FFF_{\text{hex}} = 25 \%$$

The calculation of the hex values is identical to the PWMH mode.

Table 185:
Conversion
Period duration/
Hex value

Frequency	Period duration	dec.	hex
8Hz	125000 μ s	62500 dec	F424 _{hex}
125Hz	8000 μ s	4000 dec	0FA0 _{hex}
1kHz	1000 μ s	500 dec	01F4 _{hex}

Frq-Cnt PWM mode

The pulse width ratio is entered via the register, whereas the frequency is set via the process data.

Frequency range: 8 Hz to 8 kHz.

Table 186:
Frq-Cnt PWM
mode

Parameters	Memory location
Pulse width ratio	R36
Frequency	Process data

The frequency in 8 Hz per digit is determined by the process output data of the control system. The number of periods output by the module are returned to the controller as process input data. The counting direction in this operating mode is determined by the sign of the output data:

8 Hz = 0x0001_{hex}

16 Hz = 0x0002_{hex}

24 Hz = 0x0003_{hex}

-8 Hz = 0xFFFF_{hex} (signed integer)

etc.

The pulses are provided at the output marked with OUTPUT, the counting direction at the UP/DOWN output. In this case there is the following correlation:

- the UP counting direction accords to level VCC
- the DOWN counting direction accords to level GND

With a rising edge of bit 0 of the control byte, the process input data are set to the value of the process output data (process data operation, i.e. bit 7 of the control byte is 0).

The pulse-width ratio is determined via register R36 and remains constant. Modifications will only be effective after a re-start of the module.

Frq-Cnt Pulse Mode

The pulse length is entered via the register, whereas the frequency is set via the process data.

Frequency range: 8 Hz to 8 kHz.

Table 187:
Frq-Cnt Pulse
Mode

Parameters	Memory location
Pulse width	R37
Frequency	Process data

Pulse width: 1 Digit = 2 ms

The frequency in 8 Hz per digit is determined by the process output data of the control system. The number of pulses output by the module are returned to the controller as process input data. The counting direction in this operating mode is determined by the sign of the output data:

- 8 Hz = 0x0001_{hex}
- -8 Hz = 0xFFFF_{hex} (signed integer)

The pulses are provided at the output marked with OUTPUT, the counting direction at the UP/DOWN output. In this case there is the following correlation:

- the UP counting direction accords to level VCC
- the DOWN counting direction accords to level GND

With a rising edge of bit 0 of the control byte, the process input data are set to the value of the process output data (control byte in process data operation, i.e. bit 7 = 0). The pulse width applying to all frequencies is determined by R37 in increments of 2 μ s per digit.



Note

Modifications will only be effective after a re-start of the module.

Calculation example:

1 Adjustment of the pulse width:

$$10 \text{ ms} = 10\,000 \mu\text{s}$$

2 Digit [dec] = Pulse width [μs]
/Conversion factor [here 2 μs]

$$\text{Digit} = 10\,000 \mu\text{s} / 2 \mu\text{s}$$

$$= 5000_{\text{dec}}$$

$$= \underline{\underline{1388}}_{\text{hex}}$$

=> This value is now entered in register R37.

Cnt-Cnt-PWM Mode

The pulse width ratio and the frequency are entered via the register, whereas the pulse number is set via the process data.

Table 188:
Cnt-Cnt-Pulse
Mode

Parameters	Memory location
Pulse width ratio	R36
Period duration	R35
Number of pulses	Process data

The number of pulses is determined by the process output data. The number of periods output by the module are returned to the controller as process input data. The pulse width ratio and period duration are set as follows:

- Pulse width ratio via register R36
- Period duration via register R35 (1 Digit = 0.25 μ s).

The frequency range is specified with 1 kHz to 32 kHz.

A positive edge of bit 0 of the control byte triggers the pulse output. With each further edge, this can re-triggered. The pulses are provided at the output marked with OUTPUT. The UP/DOWN output can be set via bit 2 of the control byte.

The controller is provided with status information, i.e. acceptance and simultaneous start of the pulse output, via bit 0 of the status byte. Bit 1 of the status bytes remains set as long as the output is active. Bit 2 of the status byte indicates the status of channel 1.

Pulse width ratio in the process data

Input format: Two's complement representation (the integer value "1" is reproduced as 9xFFFF).

The ratio between duty cycle/period duration is determined with a maximum resolution of 10 bits.

<i>Table 189: Pulse width ratio</i>	Process data	Output value
	0x0000	0 % Duty-Cycle
	0x3FFF	50 % Duty-Cycle
	0x7FFF	100 % Duty-Cycle

Output power (Derating)

When using PWM modules, the power loss within the module must be considered.

The maximum current value for the "inductive worst case", e.g. when using proportional valves, is shown in the following schematic.

In an ohmic load situation the line is horizontal at 2.5, independent of the frequency.

Figure 74:
Derating
Characteristic
curve

Current value
depending on the
duty cycle

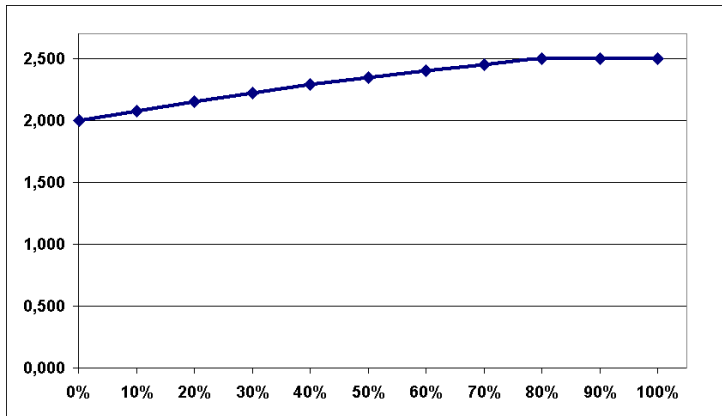

Attention

Please note that the modules with hardware status D.xxxxxx00 feature the following different derating.

When using PWM modules with hardware status D.xxxxxx00, the power loss within the module must be considered.

It is composed of three factors and may not exceed 1 W
 ($P = P_I + P_f + P_L$):

- Current-dependent losses

$$P_I = I_{\max}^2 \times 0.15 \Omega$$

- Frequency-dependent losses

$$P_f = U \times I_{\max} \times 10^{-6} \text{sec} \times f$$

- Inductive recovery

$$P_L = I_{\max}^2 \times L / (2 \times f)$$

Legend

I_{\max} : Max. output current (observe duty cycle)

U: Output voltage

f: Frequency

L: Inductivity

The inductive component dissipates via an internal 39 V diode. Via an external Schottky diode with an according power loss rating and voltage (min. 45 V), the energy can be converted externally.

Connection is established via the cathode on pin 4 and the anode on pin 3.

Illustration of the possible frequencies depending on the output current (for various duty cycles).

Figure 75:
 Derating without
 inductive
 component

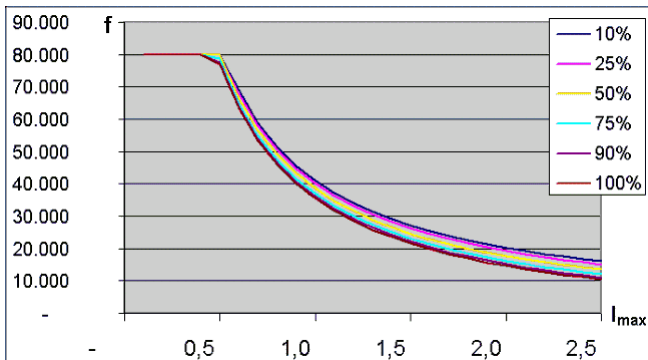
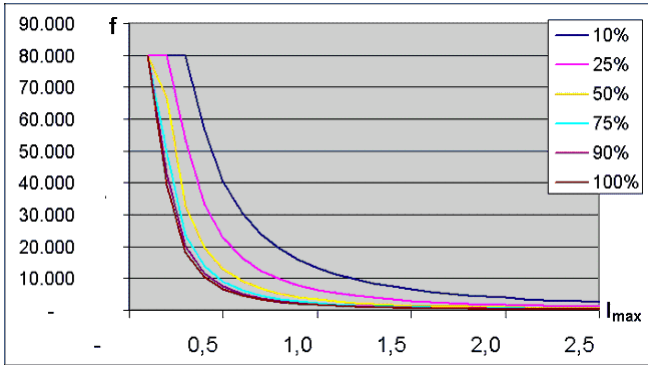

Figure 76:
Derating at 1 mH
inductive load



Parameters

Detailed information on fieldbus-dependent parameterisation of the modules is contained in the chapter "Parameters of the *piconet*[®] I/O modules" of the following manuals:

- Profibus-DP
German: „*piconet*[®] for PROFIBUS-DP“, D300775
English: „*piconet*[®] for PROFIBUS-DP“, D300776
- DeviceNet
Not yet published
- CANopen
Not yet published

Diagnosis

Diagnostics via LEDs

Please read the description of the diagnostic LEDs in the event of local errors of the coupling and extension modules in Chapter 5 of this manual: Fieldbus-specific diagnostic indications via LEDs are described in the chapter "Error treatment and diagnostics" of the above mentioned manuals.

Diagnostics via software

Detailed information on fieldbus-dependent diagnostics of the modules is contained in the chapter "Error treatment and diagnostics" of the above mentioned manuals.

Data mapping



Note

Data mapping of the *piconet*[®] modules depends on the type of fieldbus.

For this, please refer to the mapping descriptions in chapter "Data mapping of the *piconet*[®] modules" of the respective bus-specific manuals.

Control and status byte

The control and status byte are only visible, if the module is operated in the complex mode.

The control byte is contained in the output image and can be read or written.

The status byte is contained in the input image and can only be read.

Process data operation

- Control byte

<i>Table 190: Control byte PWM module</i>	Bit	7	6	5	4	3	2	1	0
	Name	RegAccess	0	0	0	0	0	0	Start pulses

<i>Table 191: Meaning of the control byte bits</i>	Name	Description
	RegAccess	0 = Register communication disabled, process data operation
	Start pulses	In the Cnt_Cnt_PWM mode a positive edge of this bit triggers pulse output. With each further positive edge, this can be re-triggered.

■ Status byte

<i>Table 192: Status byte PWM encoder</i>		Bit	7	6	5	4	3	2	1	0
	Name	RegAccess	Error	OVR_TEMP_ERR-	0	StateCh1	OUT	Start	pulses	

<i>Table 193: Meaning of the status byte bits</i>	Name	Description
	RegAccess	0 = Acknowledgement of process data operation
	Error	0 = general error bit, error applies
	OVR_TEMP_ERR	0 = no error 1 = Over-temperature in module, outputs are switched off.
	StateCh1	In the Cnt_Cnt_PWM mode the status of channel 1 is checked back.
	OUT	In the Cnt_Cnt_PWM mode the status of the output is shown (1 = write).
	Start pulses	In the Cnt_Cnt_PWM mode the status of bit 0 of the control byte is shown.

Register communication

■ Control byte

<i>Table 194: Control byte PWM module</i>		Bit	7	6	5	4	3	2	1	0
	Name	RegAccess	R/W	Register number						



*Table 195:
Meaning of the
control byte bits*

Name	Description
RegAccess	1 = Register communication enabled, no process data operation
R/W	0 = Read: Registers can be read 1 = Write: Registers can be written
Register number	Number of the register that is to be read or written.

■ Status byte

*Table 196:
Status byte
PWM module*

Bit	7	6	5	4	3	2	1	0
Name	RegAccess	R/W						Register number

*Table 197:
Meaning of the
control byte bits*

Name	Description
RegAccess	1 = Acknowledgement for register access
R/W	0 = Read: Register has been read
Register number	Number of the register that has been read or written.

Register overview of the PWM module

Table 198:
Register overview

Register	Designation	Default R/W		Memory
		value		
		(in hex)		
R0	reserved	0000	R	RAM
R1	reserved	0000	R	RAM
R2	Period duration	Variable	R/W	RAM
R3	Fundamental frequency	Variable	R/W	RAM
R4	reserved	Variable	R/W	RAM
R5	PWM non-linearised value	Variable	R/W	RAM
R6	Diagnostic register - not used	0000	R	RAM
R7	Command register - not used	0000	R	RAM
R8	Module type	09D0	R	ROM
R9	Software version	XXXX	R	ROM
R10	Multiplex shift register	0218	R	ROM
R11	Signal channels	0218	R	ROM
R12	Minimum data length	1818	R	ROM
R13	Data structure	0000	R	ROM
R14	reserved	0000	R	
R15	Alignment register	Variable	R/W	RAM
R16	Hardware version number	XXXX	R/W	SEEROM

R17	reserved	0000	R	
R18	reserved	0000	R	
R19	Manufacturer scaling: Offset	0000	R/W	
R20	Manufacturer scaling: Gain	0000	R/W	
R21	reserved	0000	RW	
...
R31	Code word register	Variable	R/W	ROM
R32	Feature register	0004	R/W	SEEROM
R33	User offset	0000	R/W	SEEROM
R34	User gain	0000	R/W	SEEROM
R35	Period duration PWM	0FA0	R/W	SEEROM
R36	Duty cycle	0000	R/W	SEEROM
R37	Pulse duration	0000	R/W	SEEROM
R38 to R63	reserved	0000		

Feature register (R32)

The basic settings of the module can be modified in the feature register. In order to write the register, it is required to reset the write-protection via the codeword register. Default 0x0004

Table 199:
Feature register
PWM module

A Default
setting

Bit	Value	Description
0		User scaling
	0	Inactive A
	1	Active
1		Manufacturer scaling
	0	Inactive A
	1	Active
2		Watchdog
	0	Inactive
	1	Watchdog active A If the module does not receive any data for 100 ms, then the PWM signal is set to 0% ON-period.
12-3		reserved
15, 14, 13		Operating mode Frequency range
	000	„PWMH Mode“ A , Page 12-63 1 kHz to 80 kHz
	001	„PWML Mode“, Page 12-65 8 Hz to 1 kHz
	011	„Frq-Cnt PWM mode“, Page 12-66 8 Hz to 8 kHz
	101	„Frq-Cnt Pulse Mode“, Page 12-67 8 Hz to 8 kHz
	111	„Cnt-Cnt-PWM Mode“, Page 12-69 1 kHz to 32 kHz

**Sxxx-0202D-x003,
Up/down counter, 24 VDC, 100 kHz**

The module Sxxx-0202D-x003 is equipped with two fast counters up to 100 kHz. It counts binary pulses and transfers the count value to the higher level automation device.

The input V/R can be used to select between up/down counting (32 bit).

The counters can be triggered via gate signals (gate inputs). Depending on the gate input level the counter function is inhibited or activated.

The outputs can be switched or pulsed depending on the counter value and can thus be used for fast control signals for field devices.

Counter values and outputs can be set and counter functions can be triggered and disabled via the controller. The module indicates the signal status of the inputs and outputs via LEDs.

The module is either parameterised via the fieldbus or the additional configuration tool "I/O-ASSISTANT" via the configuration interface.

Parameters are stored permanently in the module, even in the event of a power failure.

Figure 77:

SDPB-0202D-x003;

SNNE-0202D-x003

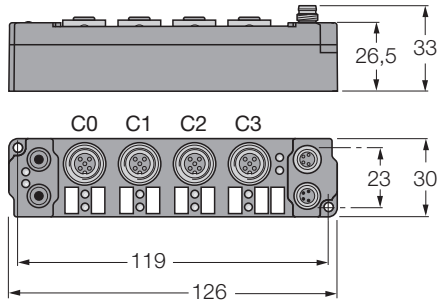
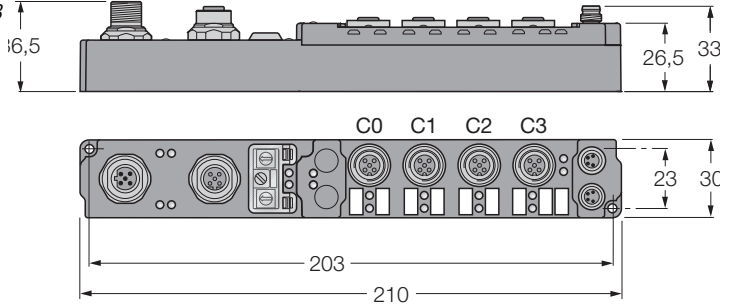

Technical data

<i>Table 200:</i> <i>Technical data</i> <i>Sxxx-0202D-x003</i>	Designation	Sxxx-0202D-x003
	Voltage supply	
	Operating voltage U_B	24 VDC (-15 %/+20 %)
	Load voltage U_L	24 VDC (-15 %/+20 %)
	Number of counters	2 mit 32 bit counting depth each
	Switching frequency	100 kHz (2 kHz during selection of up/down)
	Number of inputs	2 counter inputs, 2 gate inputs, 2 up/down selector switches
	Nominal input voltage	24 VDC (-15 %/+20 %)
	Signal voltage "0"	-3 V to 5 V (EN 61131-2, type 2)
	Signal voltage "1"	11 V to 30 V (EN 61131-2, type 2)
	Number of outputs per counter	1 output, 0.5 A max. short-circuit protected
	Sensor supply	via operating voltage, total 0.5 A max., short-circuit protection
	Current consumption	80 mA. typ. load voltage
	Bytes in the process image	- Only complex: 4 input and 4 output data bytes per channel + 1 status and 1 control byte per channel
	Potential isolation	- Channels/Operating voltage: no - Between the channels: no - Operating voltage/fieldbus: yes

Wiring diagram

Figure 78:
Pin configuration

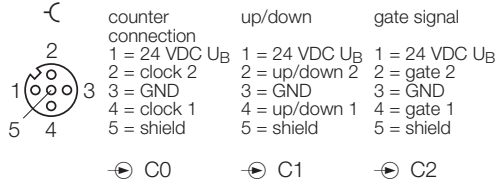

Outputs:

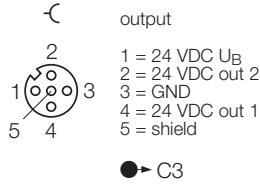

- The counter pulses of counter 1 and 2 are connected via socket A (counter connection).
- The counting direction (up/down) is determined via socket B.
- The gate signal can "freeze" the count, i.e. the clock signals are ignored, at socket 3.
- The outputs are provided at socket D.
- The outputs are powered via U_L . The module and the signals for the sensor are powered via U_B .

Meaning of the LEDs

Table 201:
Channel LED
indications

LED	Status	Meaning
C	Green	Pulse count indication.
	OFF	No counting procedure.
U	Green	The counter counts upwards.
D	Green	The counter counts downwards.
G	Green	The gate input is HIGH.
Q	Green	Output 1 and/or output 2 are set.

Function principle

The module is counting binary pulses and transfers the updated value to the higher level control.

There are two independent 32-bit up/down gated counters available. A low or high level at the GATE input will stop the respective counter, depending on the setting in the feature register (bit 8) of the channel.

The counting direction can be controlled via separate inputs (low level = up; high level = down) In addition 2 digital outputs can be set.

The max. input frequency is limited to 100 kHz; the minimum pulse width of the input signal is specified with approx. 1 microsecond. The counters react to a rising edge of the input signal.

The counter value can be set (control byte, bit 5), the counting function can be inhibited (control byte, bit 4) and the outputs can be activated (control byte, bit 2) via the control byte and the controller. Further it is possible to activate an internal function (control byte, bit 0), which enables automatic setting of outputs at defined counter values. Via bit 2 in the feature register it is further possible to define whether the counters are edge-triggered or status-controlled.

Internal functions

- Setting/re-setting of an output and reset of the counter



Note

The counter can only be set/reset in the upwards counting direction.

With activated internal function (control byte, bit 0) the outputs are set or reset depending on the settings in the feature register (bit 4 to bit 6) and the preset values in registers 35-38. The bit for setting the output (control byte, bit 2) is then disabled. Registers 39 and 40 determine the values at which the counter is set to zero; this function is only activated via bit 6 in the feature register and does not depend on the control byte.

Pulse mode

If the pulse mode is activated (register 32, bit 7 and control byte, bit 0), the respective output is set depending on the preset values in registers 35 and 36 to a pre-defined pulse length (setting in register 41, unit: 1 $\mu\text{s}/\text{digit}$ or 64 $\mu\text{s}/\text{digit}$ (timer factor, R32, bit 9), shortest pulse: 250 μs , maximum pulse: 4 s). Bits 4 and 5 of the feature register have no function in this case. The counter values are reset in the same manner.

Bit 10 of the feature register affects the switch-off performance of the output. The output can be reset via a counter reset or after expiry of the pulse period.

The preset values of registers 35 to 41 are copied to registers 0 to 4 following a power ON reset (see register overview). These may be modified during operation.



Note

After the feature register or other register values, which are stored in the EEPROM, have been modified it is always required to carry out a power ON reset to accept these values.

Process data

With the counter module, 5 bytes (4 bytes user data and 1 byte control/status) are mapped. If there is no process data exchange for 100 ms (activation via bit 3 of the feature register), the watch-dog will switch off the outputs.

Parameters

Detailed information on fieldbus-dependent parameterisation of the modules is contained in the chapter "Parameters of the *piconet*[®] I/O modules" of the following manuals:

- Profibus-DP
German: „*piconet*[®] for PROFIBUS-DP“, D300775
English: „*piconet*[®] for PROFIBUS-DP“, D300776
- DeviceNet
Not yet published
- CANopen
Not yet published

Diagnosis

Diagnostics via LEDs

Please read the description of the diagnostic LEDs in the event of local errors of the coupling and extension modules in Chapter 5 of this manual: Fieldbus-specific diagnostic indications via LEDs are described in the chapter "Error treatment and diagnostics" of the above mentioned manuals.

Diagnostics via software

Detailed information on fieldbus-dependent diagnostics of the modules is contained in the chapter "Error treatment and diagnostics" of the above mentioned manuals.

Data mapping



Note

Data mapping of the *piconet*[®] modules depends on the type of fieldbus.

For this, please refer to the mapping descriptions in chapter "Data mapping of the *piconet*[®] modules" of the respective bus-specific manuals.

Control and status byte

The control and status byte are only visible, if the module is operated in the complex mode.

The control byte is contained in the output image and can be read or written.

The status byte is contained in the input image and can only be read.

Process data operation

- Control byte

Table 202:
Control byte
Counter module

Bit	7	6	5	4	3	2	1	0
Name	RegAccess	0	CNT_SET	CNT_INH	GATE_A	SET_A	0	EN_A

Table 203:
Meaning of the
control byte bits

Name	Description
RegAccess	0 = Register communication disabled, process data operation
CNT_SET	The module is set to the value determined by the process data. The counter settings can be edge or level-triggered (bit 3 of the feature register). <ul style="list-style-type: none"> - Level-triggered: The counter module accepts the preset values, the counter is disabled until a reset of the CNT_SET bit. - Edge-triggered: The counter module accepts the preset values upon a positive edge of the SCNT_SET bit. The counter can then immediately continue counting.
CNT_INH	The counter is stopped when this bit is active. The previous count is retained.
GATE_A	Bit = 1: → The state of the Gate input is shown in Bit 3 of the status byte (S××B-0202D-××××: from version D.xxxxxx23 SNNE-0202D-××××: from version D.xxxxxx11).
SET_A	Setting the output
EN_A	Via this bit the internal functions in register 32 are enabled.

■ Status byte

Table 204:
Status byte
Up/down counter

Bit	7	6	5	4	3	2	1	0
Name	RegAccess	0	SET_ACC	INH_ACC	GATE_ST	ST_A	ST_V/R	0

Table 205:
Meaning of the
status byte bits

Name	Description
RegAccess	0 = Acknowledgement of process data operation
SET_ACC	Data to set the counter have been accepted by the module.
INH_ACC	The counter is stopped when this bit it set.
GATE_ST	Shows the actual state of the Gate input.
ST_A	The output status is reproduced by this bit.
ST_V/R	The status of the V/R input is reproduced by this bit.

Register communication

■ Control byte

Table 206:
Control byte
Counter module

Bit	7	6	5	4	3	2	1	0
Name	RegAccess	R/W	Register number					

Table 207:
Meaning of the
control byte bits

Name	Description
RegAccess	1 = Register communication enabled, no process data operation
R/W	0 = Read: Registers can be read 1 = Write: Registers can be written
Register number	Number of the register that is to be read or written.

■ Status byte

*Table 208:
Control byte
Counter module*

Bit	7	6	5	4	3	2	1	0
Name	RegAccess	R/W						Register number

*Table 209:
Meaning of the
status byte bits*

Name	Description
RegAccess	1 = Acknowledgement for register access
R/W	0 = Read: Register has been read
Register number	Number of the register that has been read or written.

Register overview

Table 210:
Register overview

Register	Designation	Default R/W		Memory
		value		
		(in hex)		
R0	Switch-on threshold, least significant word	Variable	R/W	RAM
R1	Switch-on threshold, most significant word	Variable	R/W	RAM
R2	Switch-off threshold, least significant word; pulse length (1 μ s/digit)	Variable	R/W	RAM
R3	Switch-off threshold, most significant word	Variable	R/W	RAM
R4	Reset threshold, least significant word	Variable	R/W	RAM
R5	Reset threshold, most significant word	Variable	R/W	RAM
R6 and R7	reserved	0000	R	RAM
R8	Module type	05DE	R	ROM
R9	Software version	XXXX	R	ROM
R10	Multiplex shift register	0228	R	ROM
R11	Signal channels	0228	R	ROM
R12	Minimum data length	2828	R	ROM
R13	Data structure	0006	R	ROM
R14	reserved	0000	R	
R15	Alignment register	Variable	R/W	RAM
R16	Hardware version number	XXXX	R/W	EEPROM

R17 to R30	reserved	0000	R	
R31	Code word register	Variable	R/W	ROM
R32	Feature register	0104	R/W	EEPROM
R33 and R34	reserved	0000	R	
R35	Switch-on threshold, least significant word	0000	R/W	EEPROM
R36	Switch-on threshold, most significant word	0000	R/W	EEPROM
R37	Switch-off threshold, least significant word	0000	R/W	EEPROM
R38	Switch-off threshold, most significant word	0000	R/W	EEPROM
R39	Reset threshold, least significant word	0000	R/W	EEPROM
R40	Reset threshold, most significant word	0000	R/W	EEPROM
R41	Pulse length (1 μ s or 64 μ s/digit)	00FA	R/W	EEPROM
R42 to R47	reserved	0000	R	



Attention

The threshold values should not be entered directly in registers 0 to 5.

In case of a power reset of the module, the actual changes in the RAM could be overwritten by invalid values of registers 35 to 40 stored in the EEPROM.

Feature register (R32)

The basic settings of the module can be modified in the feature register. In order to write the register, it is required to reset the write-protection via the codeword register.

Default 0x0108

Table 211:
Feature register
counter module

A Default
setting

Bit	Value	Description
0		reserved
1		reserved
2		Watchdog
	0	Active A
	1	Inactive
3		Setting the counter
	0	Positive signal: The counter is set upon a positive signal of the CNT_SET bit in the control byte.
	1	Positive edge: The counter is set upon a positive edge of the CNT_SET bit in the control byte A . Only the momentary actual process value is accepted.
4		Setting the output
	0	Inactive A
	1	Active
5		Resetting the output
	0	Inactive A
	1	Active
6		Resetting the counter
	0	Inactive A
	1	Active

Bit	Value	Description
7		Pulse mode
	0	Inactive A
	1	Active
8		Disable counter
	0	Gate 0: Counter is disabled if the input gate is 0.
	1	Gate 1: Counter is disabled if the input gate is 1. A
9		Timer basis (pulse length register 41):
	0	1 μ s/digit (250 μ s - 65 ms) A
	1	64 μ s/digit (10 ms - 4 s)
10		Resetting via a Reset
	0	Inactive A The output is reset via a reset of the counter
	1	Active The output is reset after expiry of the pulse time
11 to 15		reserved

Description of the watch-dog

The ex factory settings include an active watch-dog timer. Following a watch-dog overflow (>100 ms) the output is reset.

Function register

■ ON/OFF/Reset operation (RAM)

Table 212:
ON/OFF/Reset
operation (RAM)

Register	Meaning	Location	Memory
R0	Switch-on threshold	Low word	RAM
R1	Switch-on threshold	High word	RAM
R2	Switch-off threshold	Low word	RAM
R3	Switch-off threshold	High word	RAM
R4	Reset threshold	Low word	RAM
R5	Reset threshold	High word	RAM

■ ON/OFF/Reset operation (EEPROM)

Table 213:
ON/OFF/Reset
operation
(EEPROM)

Register	Meaning	Location	Memory
R35	Switch-on threshold	Low word	EEPROM
R36	Switch-on threshold	High word	EEPROM
R37	Switch-off threshold	Low word	EEPROM
R38	Switch-off threshold	High word	EEPROM
R39	Reset threshold	Low word	EEPROM
R40	Reset threshold	High word	EEPROM



Note

A counter underrange will not trigger a reset of the counter value, i.e. the automatic setting of the counter to zero is only triggered if the reset value is overranged.



Note

The following threshold values must be respected:
Switch-on threshold < Switch-off threshold < Reset threshold

■ Pulse/Reset operation (RAM)

Table 214:
Pulse/Reset
operation (RAM)

Register	Meaning	Location	Memory
R0	Switch-on threshold	Low word	RAM
R1	Switch-on threshold	High word	RAM
R2	Pulse length	1/64 μ s/digit	RAM
R3	-	-	-
R4	Reset threshold	Low word	RAM
R5	Reset threshold	High word	RAM

■ Pulse/Reset operation (EEPROM)

Table 215:
Pulse/Reset
operation
(EEPROM)

Register	Meaning	Location	Memory
R35	Switch-on threshold	Low word	EEPROM
R36	Switch-on threshold	High word	EEPROM
R37	-	-	-
R38	-	-	-
R39	Reset threshold	Low word	EEPROM
R40	Reset threshold	High word	EEPROM
R41	Pulse length	1/64 μ s/digit	EEPROM



Note

The adjustable pulse length ranges from 0.25 ms to 4000 ms.



Note

In the pulse mode, the counter width may not exceed the counter run time, i.e.:
max. pulse length < reset threshold/counting frequency.

13 Third Party Products

CPV valve terminal from the company Festo	2
General product description.....	2
Bus connection	2
Voltage supply	2
Support.....	2
Ordering.....	3

CPV valve terminal from the company Festo

General product description

The new CPV-valve terminals from FESTO are equipped with an IP-Link interface (CPV fieldbus node) and can thus be integrated as an extension module in the *piconet*[®] fieldbus system.

Thus the valve terminals are suited for field bus systems such as PROFIBUS-DP, CANopen and DeviceNet™. Further bus systems are in preparation.

The CPV fieldbus node is used for communication between a CPV valve terminal and a *piconet*[®]-coupling module. It is used to control a CPV valve terminal with 8 valve discs and 16 valve coils and their switching status indication via LEDs.

The CPV valve terminals are controlled via an automatic current suppression which reduces the energy consumption and thermal dissipation.

The CPV valve terminals are available in two housing versions featuring identical performance characteristics.

- CPV10
- CPV14

Bus connection

Like with all *piconet*[®] extension modules, the bus connection is established via the IP-link fibre optic system.

Voltage supply

A 4-pole M8 connector (female) is used to feed the power. The supply of the internal logic and valve coils is galvanically isolated.

It is possible to power further CPV IP-link valve terminals and IP-link modules via the second M8 connector (male).

Support

The company Festo is exclusively responsible for customer support regarding the valve terminals.

Ordering

The CPV valve terminals are exclusively sold via the company Festo AG & Co..



Note

Detailed information on installation, set-up, configuration and diagnostics of the valve terminals can be taken from the product descriptions of the company Festo (534516 de 0211NH [667270]). These can be downloaded via www.festo.com.

14 Appendix

Module types	2
Nominal current consumption of the <i>piconet</i>[®] modules.....	3
Description of the module parameters	6
Module-independent user parameters	6
Digital coupling modules	7
Analogue input modules.....	8
– Sxxx-40A-0005	8
– Sxxx-40A-0007	9
– Sxxx-40A-0004	9
– Sxxx-40A-0009	10
Analogue output modules Sxxx-04A-000x	11
– Sxxx-04A-0007/Sxxx-04A-0009	11
Technology modules	12
– Sxxx-10S-0002, RS232 interface	13
– Sxxx-10S-0004, RS485/42 interface	14
– Sxxx-0202D-0003, up/down counter 24 VDC	15

Module types

Table 216:
Module types

Module type		Designation	Function
hex.	dec.		
Analogue input modules			
0C1E	3102	Sxxx-40A-x005	4-port analogue input module, differential inputs - 10 V to + 10 V
0C28	3112	Sxxx-40A-x007	4-port analogue input module, differential inputs 0/4 to 20 mA
0C82	3202	Sxxx-40A-x009	4-port analogue input module for Pt100 (RTD)
0CF0	3312	Sxxx-40A-x004	4-port analogue input module for thermocouples
Analogue output modules			
1024	4132	Sxxx-04A-x007	4-port analogue output module, -10 V to +10 V
1010	4112	Sxxx-04A-x009	4-port analogue output module, 0/4 to 20mA
Technology modules			
13F5	5109	Sxxx-10S-x001	1-channel incremental encoder interface
1772	6002	Sxxx-10S-x002	1-channel RS232 interface
1786	6022	Sxxx-10S-x004	1-channel RS485/422 interface
1391	5009	Sxxx-10S-x005	1-channel SSI interface
09D0	2512	Sxxx-0002D-x002,	2-channel pulse width output 24 VDC/ 2.5 A
05DE	1502	Sxxx-0202D-x003	Up/down counter, 24 VDC, 100 kHz

Nominal current consumption of the *piconet*® modules

It is important to consider the current consumption of the individual modules for power-feed through calculations, module protection and assessment of the voltage drop on the power cable.

The following tables show the nominal current ratings of the modules at 24 VDC.

The sensor supply or the current for outputs must be added to the specified ratings.

■ Stand-alone modules

Table 217:
Nominal current
ratings of the
stand-alone
modules

	Profibus-DP
Digital input modules	$I_B = 85 \text{ mA}$ $I_L = 5 \text{ mA}$
Digital output modules	$I_B = 90 \text{ mA}$ $I_L = 5 \text{ mA}$
Digital combined modules	$I_B = 90 \text{ mA}$ $I_L = 5 \text{ mA}$
Analogue input modules	
- SxxB-40A-x005 (-10 V to +10 V)	$I_B = 140 \text{ mA}$
- SxxB-40A-x007 (0/4 to 20 mA)	$I_L = 5 \text{ mA}$
- SxxB-40A-x004 (Thermo)	$I_B = 110 \text{ mA}$
- SxxB-40A-x009 (Pt100)	$I_L = 5 \text{ mA}$
Analogue output modules	
- SxxB-04A-x007 (- 10 V to + 10 V)	$I_B = 140 \text{ mA}$ $I_L = 5 \text{ m}$
- SxxB-04A-x009 (0/4 to 20 mA)	$I_B = 115 \text{ mA}$ $I_L = 35 \text{ mA}$
Technology modules	
- SxxB-10S-x001 (Incremental encoder)	$I_B = 140 \text{ mA}$ $I_L = 5 \text{ mA}$
- SxxB-10S-x002 (RS 232 Interface)	$I_B = 115 \text{ mA}$ $I_L = 35 \text{ mA}$
- SxxB-10S-x004 (RS 485/422 Interface)	$I_B = 115 \text{ mA}$ $I_L = 35 \text{ mA}$
- SxxB-10S-x005 (SSI Interface)	$I_B = 140 \text{ mA}$ $I_L = 5 \text{ mA}$
- SxxB-0002D-x002 (PWM)	$I_B = 85 \text{ mA}$ $I_L = 5 \text{ mA}$
- SxxB-0202S-x003 Up/down counter	$I_B = 85 \text{ mA}$ $I_L = 5 \text{ mA}$

■ Coupling modules

<i>Table 218:</i>		Profibus-DP
<i>Nominal current consumption of the coupling modules</i>	SxxL-0404D-x00x	$I_B = 60 \text{ mA}$
		$I_L = 5 \text{ mA}$

■ Extension modules

<i>Table 219:</i>		
<i>Nominal current consumption of the extension modules</i>	Digital input modules	$I_B = 25 \text{ mA}$
		$I_L = 5 \text{ mA}$
	Digital output modules	$I_B = 25 \text{ mA}$
		$I_L = 5 \text{ mA}$
	Digital combined modules	$I_B = 25 \text{ mA}$
		$I_L = 5 \text{ mA}$
	Analogue input modules	
	- SNNE-40A-x005 (0/4 to 20 mA)	$I_B = 55 \text{ mA}$
	- SNNE-40A-x007 (-10 V to +10 V)	$I_L = 5 \text{ mA}$
	- SNNE-40A-x004 (Thermo)	$I_B = 40 \text{ mA}$
	- SNNE-40A-x009 (Pt100)	$I_L = 5 \text{ mA}$
	Analogue output modules	
- SNNE-04A-x007 (- 10 V to + 10 V)	$I_B = 40 \text{ mA}$	
- SNNE-04A-x009 (0/4 bis 20 mA)	$I_L = 5 \text{ mA}$	
Technology modules		
- SNNE-10S-x001 (Incremental encoder)	$I_B = 55 \text{ mA}$ $I_L = 5 \text{ mA}$	
- SNNE-10S-x002 (RS 232 Interface)	$I_B = 40 \text{ mA}$ $I_L = 35 \text{ mA}$	
- SNNE-10S-x004 (RS 485/422 Interface)	$I_B = 40 \text{ mA}$ $I_L = 35 \text{ mA}$	
- SNNE-10S-x005 (SSI Interface)	$I_B = 55 \text{ mA}$ $I_L = 5 \text{ mA}$	
- SNNE-0002D-x002 (PWM)	$I_B = 25 \text{ mA}$ $I_L = 5 \text{ mA}$	
- SNNE-0202S-x003 Up/down counter	$I_B = 30 \text{ mA}$ $I_L = 5 \text{ mA}$	

Description of the module parameters

Module-independent user parameters

The following parameters are identical for all PROFIBUS-DP nodes of the *piconet*[®] system:

Table 220:
Module-
independent
parameters

Parameters	Meaning
- IP module diagnosis	Activation of module diagnostics
- Data format	With this parameter the representation format of the complex modules is adjusted. You can choose between the Intel and Motorola format.
- Updating of process image	The internal bus cycle (IP-Link) can be either trigger cyclically (process image update: asynchronous) or synchronously to receipt of the DP-Data_Exchange telegram (process image update: synchronous to cycle). If the process image is updated synchronously to the cycle, the internal bus cycle is triggered upon receipt of the Data_Exchange telegram. If asynchronous process image up-date has been selected, the bus cycle (IP-Link) is triggered independently of the Data_Exchange telegrams.
- Reaction on DP-Error	Parameterisation of possible responses to a DP-error: - Stop of the IP-Link bus - Resetting the outputs to 0 - Retaining the last output status

Digital coupling modules

Table 221:
Parameters
Digital
Coupling modules

Parameters	Meaning
– IP-Link-Error-Reaction	Controls the IP-Link module performance in the event of an IP-Link error. The IP-Link data exchange is stopped, the IP-Link inputs are set to "0" or retain their last actual value.
– SDPL-0404D-xxxx BYTE-Align	The input and output data of the digital IP-Link modules are mapped to the process data image, using a full byte input and/or output data.

Analogue input modules

Sxxx-40A-0005

Table 222:
Parameters
Sxxx-40A-0005

Parameters	Meaning
- Channel x overflow offset	- If this bit is set, the actual voltage value is monitored. The status byte indicates a possible over- / or under-range. - If this bit is not set, process data (> 0x7FFF oder > 0xFFFF) are monitored, depending on the manufacturer scaling. In this case, the status byte will also indicate a possible over- / or under-range.
- Channel x threshold x	Activates the adjusted threshold x.
- Channel x threshold x	Entry of the threshold x for channel x.

Sxxx-40A-0007

Table 223:
Parameters
Sxxx-40A-0007

Parameters	Meaning
- Channel 1 current mode	Depending on parameterisation, the module's measuring range is either 0 or 4 to 20 mA.
- Channel x overflow offset	If this bit is set, the actual voltage value is monitored. The status byte indicates a possible over- / or under-range. If this bit is not set, process data (> 0x7FFF oder > 0xFFFF) are monitored, depending on the manufacturer scaling. In this case, the status byte will also indicate a possible over- / or under-range.
- Channel x threshold x	Activates the adjusted threshold x.
- Channel x threshold x	Entry of the threshold x for channel x.

Sxxx-40A-0004

Table 224:
Parameters
Sxxx-40A-0004

Parameters	Meaning
- Cold junction compensation	Depending on parameterisation, the cold reference compensation of channel 1 applies to all 4 channels, resp. each channel has an own reference point.
- Channel x Thermocouple	Selection of the thermoelement type or the measuring range for channel x
- Channel x Siemens additional bit	If this parameter is activated, bits 0 to 2 of the process data are used for status evaluation.
- Channel x reference junction	If this parameter is activated, then cold reference compensation for the respective channel is carried out.

Sxxx-40A-0009

Table 225:
Parameters
Sxxx-40A-0009

Parameters	Meaning
– Channel x RTD	Defines the sensor type for the respective channel.
– Channel x Siemens additional bit	If this parameter is activated, bits 0 to 2 of the process data are used for status evaluation.
– Channel x overrange protection	If the temperature of 850°C is exceeded, the status bits are set accordingly and the output value is limited to 850°C.
– Channel x 4-wire	The setting depends on the type of sensor connection.
– Channel x 3-wire	The settings must be identical for all channels.
– Channel x 2-wire	

Analogue output modules Sxxx-04A-000x

Sxxx-04A-0007/Sxxx-04A-0009

Table 226:
Parameters
Sxxx-04A-000x

Parameters	Meaning
- Channel x watchdog	Monitors whether a message has been sent from the master to the module during the specified watchdog time. If this is not the case, then the module will perform as described under "Response to DP errors".
- Current modus for all channels	The measuring range is either adjusted to 0...20 mA or 4...20 mA for all module channels.
- User scaling	Activates or disables module user scaling.
- Manufacturer scaling	Activates or disables module manufacturer scaling.
- User switch-on value	Entry of the user switch-on values.

Technology modules

Sxxx-10S-0001, Incremental encoder interface

Table 227:
Parameters
Sxxx-10S-x001

Parameters	Meaning
- Disabling the counter	Depending on the parameterisation the counter is disabled if the gate input is either low or high (1).
- State input	How the input status is indicated depends on parameterisation.
- External latch function active	The external latch input "Gate/Latch" (M12 input) is activated.
- Period duration measurement active	The module is operating in the mode "Period duration measurement"
- Evaluation of the encoder signals	Either 1, 2 or 4-fold evaluation according to parameterisation
- Module function	The module operates either as an incremental encoder or as a 16 bit up/down counter, depending on parameterisation.

Sxxx-10S-0002, RS232 interface

Table 228:
Parameters
Sxxx-10S-0002

A Default
setting

Parameters	Meaning
– Baud rate	Module transmission rate adjustment.
– Data frame	Determines the number of data bits of the module.
– Stop bits	Determines the number of stop bits during data transfer.
– Status one cycle later	The status byte is copied by the module to the IP-Link shift register a cycle later than the most significant data bytes, if this parameter is activated. As a result the data transmission rate to the controller is reduced.
– XON/ XOFF send	If this parameter is activated, the XON/ XOFF protocol is supported by the module during data sending.
– XON/ XOFF receive	If this parameter is activated, the XON/ XOFF protocol is supported by the module during data receipt.
– send 16 bytes	If this parameter is activated, data from the FIFO will be sent continuously. The send buffer is filled by the controller (up to 16 bytes).

Sxxx-10S-0004, RS485/42 interface

The parameters of the module Sxxx-10S-x004 accord to those of the RS232 module Sxxx-10S-x002 (Page 14-13) with the following exception:

*Table 229:
Parameters
Sxxx-10S-0002*

Parameters	Meaning
- Half duplex	If this parameter is activated, then receipt of transferred data is suppressed.
- RS422 mode	The module is used as a point-to-point connection (RS422).

Sxxx-0202D-0003, up/down counter 24 VDC

Table 230:
Parameters
Sxxx-10S-0002

Parameters	Meaning
- Channel x watchdog	Monitors whether a message has been sent from the master to the module during the specified watchdog time. If this is not the case, then the module will perform as described under "Response to DP errors".
- Channel x set counter	The counter is set either upon a positive or negative signal of the CNT_SET bit in the control byte.
- Channel x set output	Activates or de-activates the function determining that the output is set if the switch-on threshold is reached.
- Channel x reset output	Activates or de-activates the function determining that the output is set if the switch-off threshold is reached.
- Channel x reset counter	Activates or de-activates the function determining that the counter is set if the reset threshold is reached.
- Channel x pulse mode	Activates or de-activates the pulse mode.
- Channel x disable counter	Depending on the parameterisation the counter is disabled if the gate input is either low or high (1).
- Channel x timer basis	Defines the timer basis for the pulse length in the pulse mode.
- Channel x set back with reset	Activates an output reset via a counter reset.
- Channel x power on level	Contains the switch-on threshold.

- Channel x power-off/ pulse	Contains the switch-off threshold.
- Channel x reset level	Contains the reset threshold.

15 Glossary of terms

A

Acknowledge

Acknowledgement of the receiver to confirm receipt of the signal.

Active conductive part

Conductor or conductive component that is energised during operation.

Address

A number for identification, e.g. for a memory location, a system or a module within a network.

Addressing

Allocation or setting of an address, e.g. for a module within a network.

Analogue

A value – e.g. a voltage - that is infinitely proportional. With analogue signals the value of the signal can assume any value within certain limits.

Automation device

A device for connection of inputs and outputs, which is connected within a technical process. Programmable logic controllers (PLC) belong to a certain category of automation devices.

B

Baud

Unit of measure for the transmission speed of data. One baud accords to one step per second. If one bit is transferred per step, then the baud rate is identical to the transmission rate in bit per second.

Baud rate

see "Baud".

Bidirectional

Working in both directions.

Binary code

Coding method with which the contents to be coded is reproduced in form of logical binary characters (0 and 1) or character strings. Binary codes are suited for coding of numerical and alpha-numerical characters.

Bus

A group signal line for data transfer, e.g. between the central processing unit (CPU), memory and I/O level. A bus can consist of several parallel lines for data transfer, addressing, control and power supply.

Bus cycle time

The time interval in which the master addresses and communicates with all slaves within the bus system, i.e. the time in which the master writes the slave outputs and reads the slave inputs.

Bus line

Smallest unit connected to the bus; consisting of a PLC, a coupling element to couple the modules to the bus and a module.

Bus system

The entirety of components that communicate via a bus.

C

Capacitive coupling

A capacitive (electrical) coupling occurs between two conductors with different potentials. Typical sources of interference are, for example, parallelly routed signal lines, contactors and static discharge.

Coding element

A two-part component for clear assignment of electronic and base module.

Command-capable modules

Command-capable modules are modules with an internal command routine, which are capable of executing certain commands (e.g. output of substitute values).

Configuration

Systematic arrangement of the I/O modules of a station.

CPU

The abbreviation for "Central Processing Unit". Central unit for data processing, the core component of the computer.

D

Digital

A value – e.g. of a voltage – which can only assume a certain condition, usually defined as 0 and 1.

DIN

The abbreviation for "Deutsches Institut for Normung e.V."

E

Earth

An electrotechnical term used to signify conductive earth whose electrical potential is always zero. The electrical potential of the earth can be unequal zero in the proximity of earthing systems. In this case the term "ground reference plane" would be used.

Earth electrode

One or several components which are in direct and good contact with the earth.

EIA

The abbreviation for "Electronic Industries Association". An association of companies belonging to the electronic industries in the USA.

Electrical equipment

All devices that are used for generation, conversion, transmission, distribution and use of electrical energy, such as conductors, cables, machines, control devices etc.

EMC

The abbreviation for "Electromagnetic Capability". The term EMC describes the capability of an electrical apparatus to function correctly within a certain environment without having a negative influence on the environment.

Equipotential bonding

Adaptation of the electrical levels of the frame of electrical apparatus and external conductive components via an electrical connection.

ESD

The abbreviation for "Electro Static Discharge".

Exposed conductive part

An exposed conductive part is electrically isolated from the active conductive part but can become energised in the event of an error.

F

Fieldbus

Data network at the sensor/actuator level. The fieldbus connects the field devices. The fieldbus is characterised by the high transmission reliability and real time performance.

Field supply

Supply of voltage to power the field devices as well as the signal voltage.

Force mode

A software mode, in which it is possible to set certain fixed variables of input and output modules to simulate certain system conditions.

Full duplex

Also called duplex. Physical or logical connection of two terminal points to establish a data transmission channel. Data can be sent or received simultaneously in both directions. Full duplex cables have two wires. In full duplex operation either both channels or only one channel are used. If data are transferred via a single channel, this takes place in the multiplex mode. That means that data are transferred alternately but with a very high frequency so that the impression of simultaneous data transfer is given.

G

Galvanic coupling

Galvanic coupling generally occurs if two current circuits share a common line. Typical interference sources are, for example, starting motors, static discharge, clocked devices and a potential difference between component housings and the mutual power supply.

GND

The abbreviation for "Ground" (zero potential)

Gray-Code

Binary code for reproduction of integers. Here one distinguishes between two.

Ground

All linked inactive parts of an electrical apparatus, which will not assume a touch voltage even in the event of an error.

Grounding strip

Usually a flexible braided conductor that connects the inactive parts of the electrical equipment, e.g. the door of a switching cabinet with the switching cabinet corpus.

Ground reference plane

Ground potential in the proximity of earthing systems. In contrast to the "earth", whose potential is always zero, it can have a different a potential than zero.

Grouping

A power supply module forms a new potential group. Thus the load and sensor supply can be fed separately.

GSD

The German term for device data base file (DDBF). The GSD file contains standardised descriptions of PROFIBUS modules. GSD files are used to simplify configuration of the DP master and the DP slaves.

H

Half duplex

Physical or logical connection of two terminal points to establish a data transmission channel. In contrast to full duplex operation, data can be transferred in both directions but, however, not simultaneously. Both terminal stations are equipped with a switch to toggle between sending and receiving data.

Hexadecimal

Numerical system with 16 as basis. One counts from 0 to 9 and then continues with the letters A, B, C, D, E and F.

Hysteresis

An encoder can stop at a certain point and then "swing" around this position. This will lead to a fluctuation of the count at a certain value. If a reference value is within this range of fluctuation, the associated output will switch on and off in the rhythm of the oscillation.

I

I/O

The abbreviation for "Input/Output".

Impedance

The impedance of a component or a circuit of several components for an AC current of a certain frequency.

Inductive coupling

An inductive (magnetic) coupling between two current-carrying conductors. The magnetic effect caused by the currents induces an interference voltage. Typical sources of interference are, for example, transformers, motors, parallelly routed power cables and high-frequency signal lines.

L

Lightning protection

All measures, that can help protect a system against damage caused by excessive voltages due to lightning.

Low impedance connection

Connection with a low AC resistance.

LSB

The abbreviation for "Least Significant Bit". The bit with the lowest significance.

M

Master

A bus station or a bus node which controls the communication between the other bus devices.

Master Slave Mode

An operating mode in which one station or node controls the communication over the bus as a master.

Mode

The operating mode of a system, component etc.

Module bus

The module bus is the internal bus of a BL67 station. The BL67 modules communicate via the module bus with the gateway. It is independent of the fieldbus.

MSB

The abbreviation for "Most Significant Bit". The bit with the highest significance.

Multimaster Mode

An operating mode in which all stations or node have equal rights to communicate over the bus.

N

NAMUR

The abbreviation for "Normen-Arbeitsgemeinschaft für Mess- und Regeltechnik". NAMUR sensors are special versions of 2-wire sensors. Due to their special construction, i.e. low internal resistance, only very few components, short housings, NAMUR initiators are particularly interference immune and provide a high level of operational safety.

O

Overhead

System administration time required by the the system for each transmission cycle.

P

Parameterisation

Determination of parameters of the individual bus stations, or their modules via the configuration software of the DP master.

PLC

The abbreviation for "Programmable Logic Controller"

Potential-free

Galvanic isolation of the reference potentials of the control and load current circuits of I/O modules.

Potential-bound

Electrical connection of the reference potentials of the control and load current circuits of I/O modules.

PROFIBUS-DP

PROFIBUS bus system with DP protocol. DP stands for "Decentralised Periphery"

The PROFIBUS-DP is based on DIN 19245 part 1+4 and was integrated in the European fieldbus standard EN 50170.

It is designed for fast cyclic data transfer between the central DP master and the remote peripheral components, i.e. the DP slaves. Consistent usage is realised by a multimaster concept.

PROFIBUS-DP address

Every PROFIBUS-DP module has a unique address via which it can be addressed by the master.

PROFIBUS-DP Master

As the central bus component, the PROFIBUS-DP master controls the access of all PROFIBUS-DP slaves to the PROFIBUS.

PROFIBUS-DP Slave

PROFIBUS-DP slaves are addressed by the PROFIBUS-DP master and exchange data with the master upon receipt of a master poll request.

Protective earth conductor

A conductor needed for protection against dangerous shock currents, signified by the abbreviation PE for "Protective Earth".

R

Radiated coupling

Radiative coupling occurs if an electromagnetic wave meets a conductor structure. The wave will induce currents and voltages in the conductor. Typical sources of interference are, for instance, sparking gaps (sparking plugs, collectors of electro-motors) and emitters (e.g. radio interference), which are operated near the affected conductor structure.

Reference potential

Potential, which serves as a reference for the measurement or assessment of the voltage of all connected circuits.

Response time

In a bus system this term is used to define the time interval between sending a read command and the receipt of a response. If referring to an input module, it describes the time interval between a signal change at the module input and the signal output to the bus system.

Repeater

Amplifier for signals transferred via the bus.

RS 485

Serial interface according to EIA standards for fast data transfer via several transmitters.

S

Serial

This term is used to define a data transmission mode with which data are transferred consecutively - bit by bit - via a cable.

Shield

This term is used to describe the conductive sheath of cables, casings and cabinets.

Shielding

The entirety of all measures and equipment used to connect the system parts to the shield.

Short-circuit proof

Property of electrical apparatus. A short-circuit proof apparatus withstands the thermal and dynamic stress which can occur at its place of installation due to a short-circuit.

Slave

A bus station or a bus node that is subordinate to the master.

Station

A functional unit or module assembly consisting of several components.

T**Terminating resistor**

Resistor on both ends of the bus line to prevent disturbing signal reflections and to adjust bus lines. Terminating resistors must always be the physically last unit at the end of a bus segment.

Topology

Geometric construction of a network or arrangement of circuits.

U**UART**

The abbreviation for "Universal Asynchronous Receiver/Transmitter". UART is a logic circuit which is used to transform an asynchronous serial data string into a bit parallel data string or vice versa.

Unidirectional

Working in one direction.

16 Index

A

accident prevention regulations 0-2

C

Combined module 1-7

Combined modules, digital 9-1

correct operation 0-2

Correct usage to the intended purpose
..... 0-2

Coupling module 1-2

Coupling modules 6-1

E

Error diagnostics, LEDs 5-2

Extension module 1-2, 1-6

F

Flash codes 5-2

I

Incremental encoder 12-5

Input modules, analogue 10-1

Input modules, digital 7-1

IP-Link 1-4, 2-2

IP-Link, cables 2-9

IP-link, connector 2-10

IP-Link, cycle time 2-5

IP-Link, line structure 2-4

IP-Link, ring structure 2-3

IP-Link, system construction 2-3

IP-Link, system expansion 1-6

IP-Link, technical data 2-8

IP-Link, topology 2-3

L

LEDs 5-2

Local errors, coupling module 5-3

Local errors, extension module 5-5

M

Mounting 0-2

O

Output modules, analogue 11-1

Output modules, digital 8-1

P

Power loss, power cable 4-8

Pulse width output 12-57

R

Register communication 3-8

Register description, general 3-3

RS232 interface 12-20

RS485/422 interface 12-36

S

safety regulations 0-2

set-up 0-2

Special function modules 12-1

Specialised knowledge 0-2

SSI interface 12-45

Staff, qualified 0-2

Stand-alone module 1-7

Start-up performance 4-9

storage 0-2

Supply voltage 4-4

symbols 0-3

System overview 1-2

T

Technical data, general 4-2

U

Up/down counter 12-81

TURCK

**Industrial
Automation**

TURCK WORLD-WIDE HEADQUARTERS

GERMANY

Hans Turck GmbH & Co. KG
Witzlebenstraße 7
D-45472 Mülheim an der Ruhr
P. O. Box 45466 Mülheim an der Ruhr
Phone (+49) (208) 4952-0
Fax (+49) (208) 4952-2 64
E-Mail more@turck.com

www.turck.com

D300778 0613



Subject to change without notice